

# E51

## Compact Bi-Directional Power and Energy Meter



### **⚠ DANGER ⚡**

#### **HAZARD OF ELECTRIC SHOCK, EXPLOSION, OR ARC FLASH**

- Follow safe electrical work practices. See NFPA 70E in the USA, or applicable local codes.
- This equipment must only be installed and serviced by qualified electrical personnel.
- Read, understand and follow the instructions before installing this product.
- Turn off all power supplying equipment before working on or inside the equipment.
- Any covers that may be displaced during the installation must be reinstalled before powering the unit.
- Use a properly rated voltage sensing device to confirm power is off.  
**DO NOT DEPEND ON THIS PRODUCT FOR VOLTAGE INDICATION**

**Failure to follow these instructions will result in death or serious injury.**

### **NOTICE**

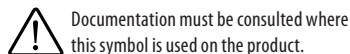
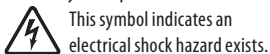
- This product is not intended for life or safety applications.
- Do not install this product in hazardous or classified locations.
- The installer is responsible for conformance to all applicable codes.
- Mount this product inside a suitable fire and electrical enclosure.

#### **FCC PART 15 INFORMATION**

**NOTE:** This equipment has been tested by the manufacturer and found to comply with the limits for a class B digital device, pursuant to part 15 of the FCC Rules. These limits are designed to provide reasonable protection against harmful interference when the equipment is operated in a residential environment. This equipment generates, uses, and can radiate radio frequency energy and, if not installed and used in accordance with the instruction manual, may cause harmful interference to radio communications. Operation of this equipment in a residential area may cause harmful interference in which case the user will be required to correct the interference at his own expense. **Modifications to this product without the express authorization of Veris Industries nullify this statement.**

For use in a Pollution Degree 2 or better environment only. A Pollution Degree 2 environment must control conductive pollution and the possibility of condensation or high humidity. Consider the enclosure, the correct use of ventilation, thermal properties of the equipment, and the relationship with the environment. Installation category: CAT II or CAT III

Provide a disconnect device to disconnect the meter from the supply source. Place this device in close proximity to the equipment and within easy reach of the operator, and mark it as the disconnecting device. The disconnecting device shall meet the relevant requirements of IEC 60947-1 and IEC 60947-3 and shall be suitable for the application. In the US and Canada, disconnecting fuse holders can be used. Provide overcurrent protection and disconnecting device for supply conductors with approved current limiting devices suitable for protecting the wiring. If the equipment is used in a manner not specified by the manufacturer, the protection provided by the device may be impaired.



#### **Installer's Specifications**

##### Measurement Accuracy:

Real Power and Energy	IEC 62053-22 Class 0.5S, ANSI C12.20 0.5%
Reactive Power and Energy	IEC 62053-23 Class 2, 2%
Current	0.4% (+0.015% per °C deviation from 25°C) from 5% to 100% of range; 0.8% (+0.015% per °C deviation from 25°C) from 1% to 5% of range
Voltage	0.4% (+0.015% per °C deviation from 25°C) from 90 V <sub>L-N</sub> to 600 VAC <sub>L-L</sub>
Sample Rate	2520 samples per second, no blind time
Data Update Rate	1 sec
Type of Measurement	True RMS One to three phase AC system

##### Input Voltage Characteristics:

Measured AC Voltage	Minimum 90 V <sub>L-N</sub> (156 V <sub>L-L</sub> ) for stated accuracy; UL Maximums: 600 V <sub>L-L</sub> (347 V <sub>L-N</sub> ) CE Maximums: 300 V <sub>L-N</sub> (520 V <sub>L-L</sub> )
Metering Over-Range	+20%
Impedance	2.5 MΩ /5 MΩ <sub>L-L</sub>
Frequency Range	45 to 65 Hz

##### Input Current Characteristics:

CT Scaling	Primary: Adjustable from 5 A to 32,000 A
Measurement Input Range	0 to 0.333 VAC or 0 to 1.0 VAC (+20% over-range)
Impedance	10.6 kΩ (1/3 V mode) or 32.1 kΩ (1 V mode)

##### Control Power:

AC	5 VA max.; 90V min. UL Maximums: 600 V <sub>L-L</sub> (347 V <sub>L-N</sub> ) CE Maximums: 300 V <sub>L-N</sub> (520 V <sub>L-L</sub> )
DC*	3 W max.; UL and CE: 125 to 300 VDC
Ride Through Time	100 msec at 120 VAC

##### Output:

Alarm Contacts	N.C., static output (30VAC/DC, 100mA max. @ 25°C, derate 0.56mA per °C above 25°C)
Real Energy Pulse Contacts	N.O., static output (30 VAC/DC, 100 mA max. @ 25°C, derate 0.56 mA per °C above 25°C)
RS-485 Port	2-wire, 1200 to 38400 baud, Modbus RTU

##### Mechanical Characteristics:

Weight	0.62 lb (0.28 kg)
IP Degree of Protection (IEC 60529)	IP40 front display; IP20 Meter
Display Characteristics	Back-lit blue LCD
Terminal Block Screw Torque	0.37 ft-lb (0.5 N-m) nominal/0.44 ft-lb (0.6 N-m) max.
Terminal Block Wire Size	26 to 14 AWG (0.13 to 2.08 mm <sup>2</sup> )
Rail	T35 (35mm) DIN Rail per EN50022

##### Environmental Conditions:

Operating Temperature	-30° to 70°C
Storage Temperature	-40° to 85°C
Humidity Range	<95% RH (non-condensing)
Altitude of Operation	3 km max.

##### Metering Category:

US and Canada	CAT III; for distribution systems up to 347 V <sub>L-N</sub> /600 VAC <sub>L-L</sub>
CE	CAT III; for distribution systems up to 300 V <sub>L-N</sub>
Dielectric Withstand	Per UL 508, EN61010
Conducted and Radiated Emissions	FCC part 15 Class B, EN55011/EN61000 Class B (residential and light industrial)
Conducted and Radiated Immunity	EN61000 Class A (heavy industrial)

##### Safety:

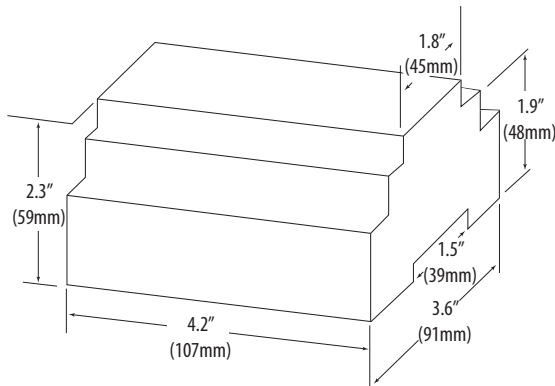
US and Canada (cULus)	UL508 (open type device)/CSA 22.2 No. 14-05
Europe (CE)	EN61010-1:2001

\* External DC current limiting is required, see fuse recommendations.

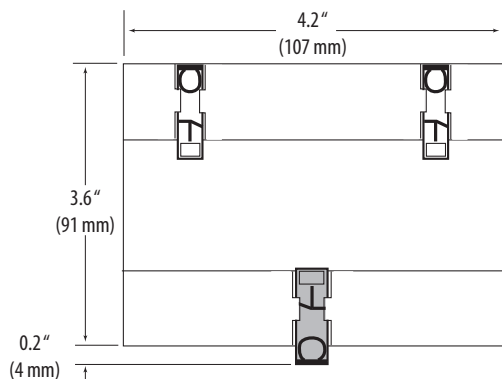
**PRODUCT IDENTIFICATION**

Model	Description	Output			Data Logging
		Pulse	RS-485	Alarm	
E51C2	Modbus output, full data set	●	●	●	
E51C3	Modbus output, data logging	●	●	●	●

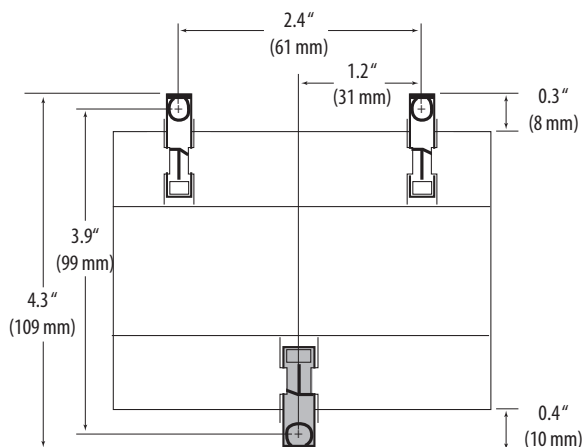
**DIMENSIONS**



*Bottom View (DIN Mount Option)*



*Bottom View (Screw Mount Option)*

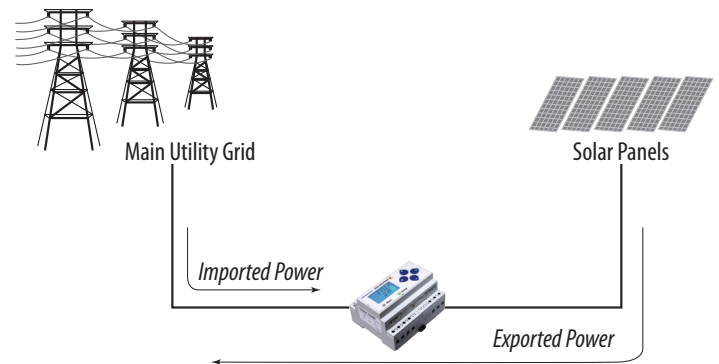


**OPERATION**

The E51 DIN Rail Power Meter provides a solution for measuring energy data with a single device. Inputs include Control Power, CTs, and 3-phase voltage. The E51 supports multiple output options, including solid state relay contacts, Modbus (with or without data logging), and pulse. The LCD screen on the faceplate allows instant output viewing.

The E51 Meter is capable of bidirectional metering. Power is monitored in both directions (upstream and downstream from the meter). The meter is housed in a plastic enclosure suitable for installation on T35 DIN rail according to EN50022. The E51 can be mounted either on a DIN rail or in a panel. **Observe correct CT orientation when installing the device.**

**APPLICATION EXAMPLE**



**DATA OUTPUTS**




- Signed Power: Real, Reactive, and Apparent 3-phase total and per phase
- Real and Apparent Energy Accumulators: Import, Export, and Net; 3-phase total and per phase
- Reactive Energy Accumulators by Quadrant: 3-phase totals and per phase
- Configurable for CT & PT ratios, system type, and passwords
- Diagnostic alerts
- Current: 3-phase average and per phase
- Volts: 3-phase average and per phase Line-Line and Line-Neutral
- Power Factor: 3-phase average and per phase
- Frequency
- Power Demand: Most Recent and Peak (Import and Export)
- Demand Configuration: Fixed, Rolling Block, and External Sync (Modbus only)

*Data Logging (E51C3 only)*

- Real Time Clock: user configurable
- 10 user configurable log buffers: each buffer holds 5760 16-bit entries (User configures which 10 data points are stored in these buffers)
- User configurable logging interval (When configured for a 15 minute interval, each buffer holds 60 days of data)
- Continuous and Single Shot logging modes: user selectable
- Auto write pause: read logs without disabling the meter's data logging mode

**PRODUCT DIAGRAM**

**INSTALLATION**

-  Disconnect power prior to installation.
-  Any covers that may be displaced during the installation must be reinstalled before powering the unit.
-  Mount the meter in an appropriate electrical enclosure near equipment to be monitored.

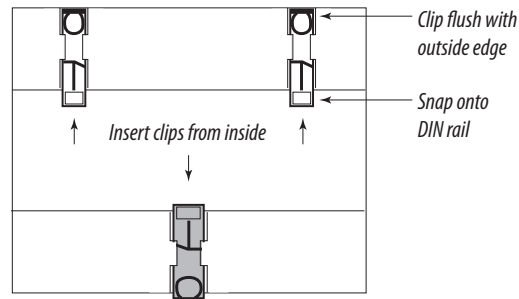
Do not install on the load side of a Variable Frequency Drive (VFD), aka Variable Speed Drive (VSD) or Adjustable Frequency Drive (AFD).

Observe correct CT orientation.

The meter can be mounted in two ways: on standard 35 mm DIN rail or screw-mounted to the interior surface of the enclosure.

**A. DIN Rail Mounting**

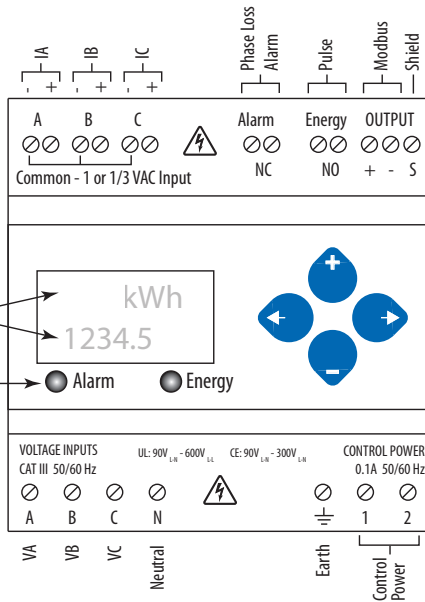
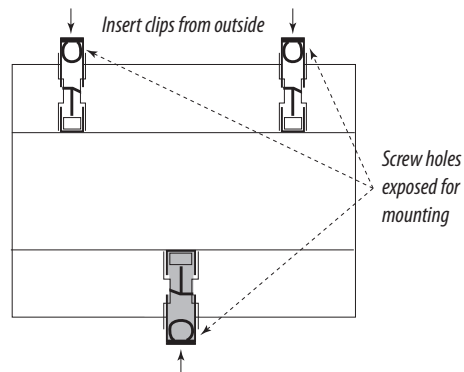
1. Attach mounting clips to the underside of the housing by sliding them into the slots from the inside. The stopping pegs must face the housing, and the outside edge of the clip must be flush with the outside edge of the housing.
2. Snap the clips onto the DIN rail. See diagram of the underside of the housing (below).



3. To prevent horizontal shifting across the DIN rail, use two Veris AV02 end stop clips.

**B. Screw Mounting**

1. Attach the mounting clips to the underside of the housing by sliding them into the slots from the outside. The stopping pegs must face the housing, and the screw hole must be exposed on the outside of the housing.
2. Use three #8 screws (not supplied) to mount the meter to the inside of the enclosure. See diagram of the underside of the housing (below).



Two 5-character rows of display text. Top row alphanumeric; Bottom row numeric only

The red Alarm LED lights when any of the 3 phase voltages drop below the selected threshold. The green Energy LED lights momentarily each time the Energy output pulse is active.

**SUPPORTED SYSTEM TYPES**

The meter has a number of different possible system wiring configurations (see Wiring Diagrams, page 5). To configure the meter, set the System Type via the User Interface or Modbus register 130 (if so equipped). The System Type tells the meter which of its current and voltage inputs are valid, which are to be ignored, and if neutral is connected. Setting the correct System Type prevents unwanted energy accumulation on unused inputs, selects the formula to calculate the Theoretical Maximum System Power, and determines which phase loss algorithm is to be used. The phase loss algorithm is configured as a percent of the Line-to-Line System Voltage (except when in System Type 10) and also calculates the expected Line to Neutral voltages for system types that have Neutral (12 & 40).

Values that are not valid in a particular System Type will display as “----” on the User Interface or as QNAN in the Modbus registers.

Number of wires	CTs		Voltage Connections			System Type		Phase Loss Measurements			Wiring Diagram
	Qty	ID	Qty	ID	Type	Modbus Register 130	User Interface: SETUP>S SYS	VLL	VLN	Balance	Diagram number
<b>Single-Phase Wiring</b>											
2	1	A	2	A, N	L-N	10	1L + 1n		AN		1
2	1	A	2	A, B	L-L	11	2L	AB			2
3	2	A, B	3	A, B, N	L-L with N	12	2L + 1n	AB	AN, BN	AN-BN	3
<b>Three-Phase Wiring</b>											
3	3	A, B, C	3	A, B, C	Delta	31	3L	AB, BC, CA		AB-BC-CA	4
4	3	A, B, C	4	A, B, C, N	Grounded Wye	40	3L + 1n	AB, BC, CA	AN, BN, CN	AN-BN-CN & AB-BC-CA	5, 6

**WIRING**

To avoid distortion, use parallel wires for control power and voltage inputs.

The following symbols are used in the wiring diagrams on the following pages.

Symbol	Description
	Voltage Disconnect Switch
	Fuse (installer is responsible for ensuring compliance with local requirements. No fuses are included with the meter.)
	Earth ground
	Current Transducer
	Potential Transformer
	Protection containing a voltage disconnect switch with a fuse or disconnect circuit breaker. The protection device must be rated for the available short-circuit current at the connection point.

**CAUTION**

**RISK OF EQUIPMENT DAMAGE**

- This product is designed only for use with 1V or 0.33V current transducers (CTs).
- DO NOT USE CURRENT OUTPUT (e.g. 5A) CTs ON THIS PRODUCT.
- Failure to follow these instructions can result in overheating and permanent equipment damage.

**WIRING DIAGRAMS**

**⚠ WARNING ⚡**

**RISK OF ELECTRIC SHOCK OR PERMANENT EQUIPMENT DAMAGE**

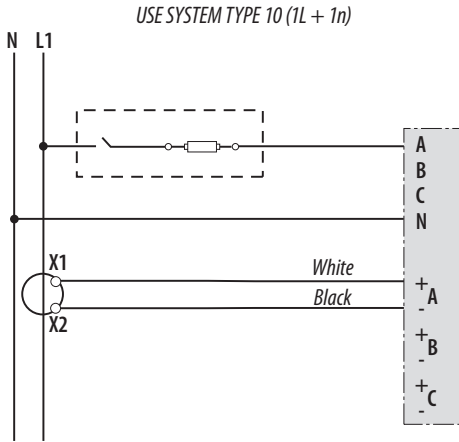
CT negative terminals are referenced to the meter's neutral and may be at elevated voltages

- Do not contact meter terminals while the unit is connected
- Do not connect or short other circuits to the CT terminals

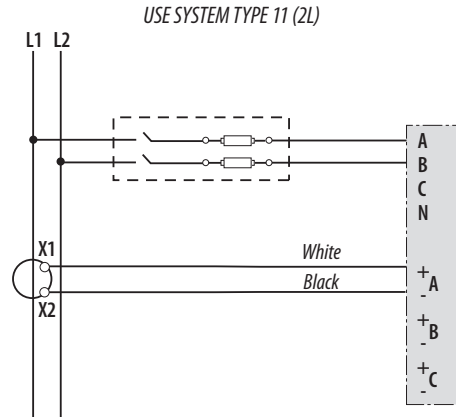
**Failure to follow these instructions may cause injury, death or equipment damage.**

Observe correct CT orientation.

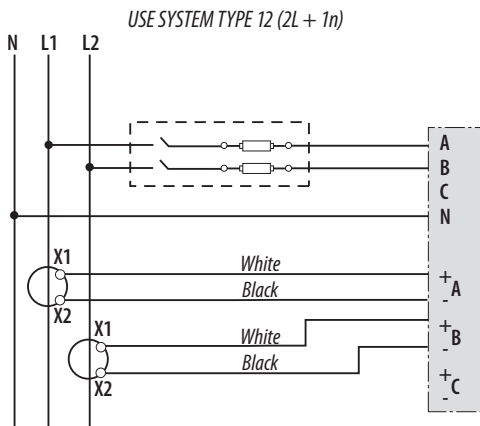
*Diagram 1: 1-Phase Line-to-Neutral 2-Wire System 1 CT*



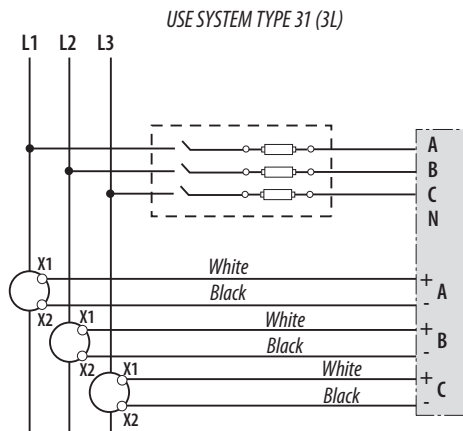
*Diagram 2: 1-Phase Line-to-Line 2-Wire System 1 CT*



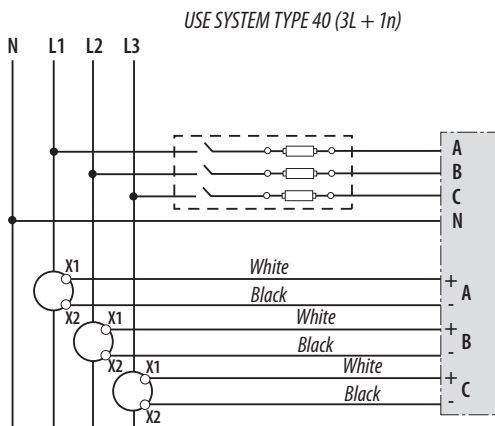
*Diagram 3: 1-Phase Direct Voltage Connection 2 CT*



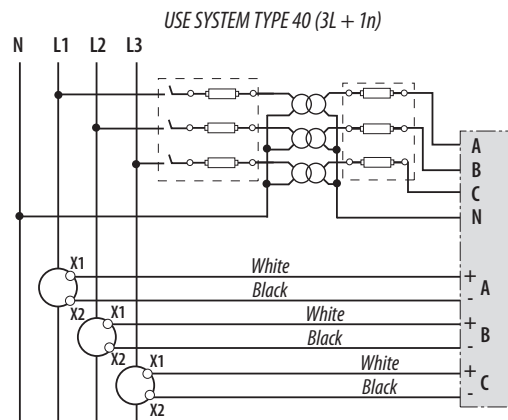
*Diagram 4: 3-Phase 3-Wire 3 CT no PT*



*Diagram 5: 3-Phase 4-Wire Wye Direct Voltage Input Connection 3 CT*

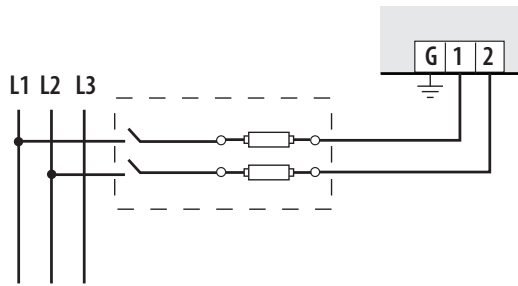


*Diagram 6: 3-Phase 4-Wire Wye Connection 3 CT 3 PT*



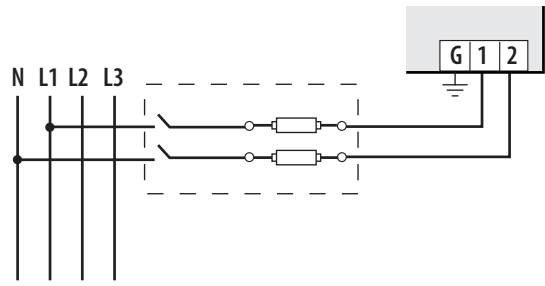
**CONTROL POWER**

Direct Connect Control Power (Line to Line)



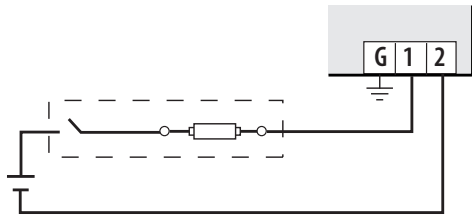
Line to Line from 90VAC to 600VAC (UL) (520VAC for CE). In UL installations the lines may be floating (such as a delta). If any lines are tied to an earth (such as a corner grounded delta), see the Line to Neutral installation limits. In CE compliant installations, the lines must be neutral (earth) referenced at less than 300VAC<sub>L-N</sub>

Direct Connect Control Power (Line to Neutral)



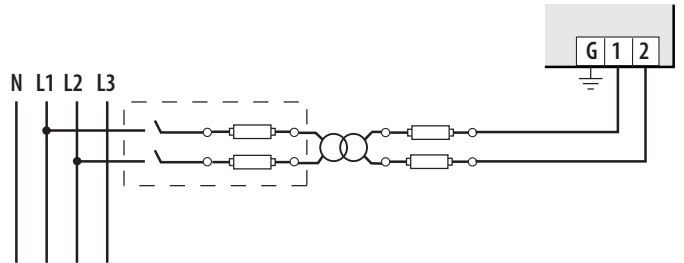
Line to Neutral from 90 VAC to 347 VAC (UL) or 300 VAC (CE)

Direct Connect Control Power (DC Control Power)



DC Control Power from 125 VDC to 300 VDC (UL and CE max.)

Control Power Transformer (CPT) Connection



The Control Power Transformer may be wired L-N or L-L. Output to meet meter input requirements

**Fuse Recommendations:**

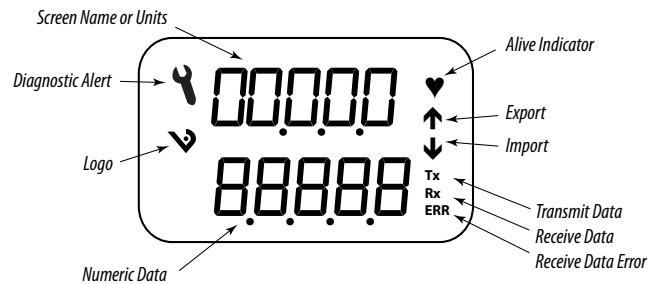
Keep the fuses close to the power source (obey local and national code requirements).

For selecting fuses and circuit breakers, use the following criteria:

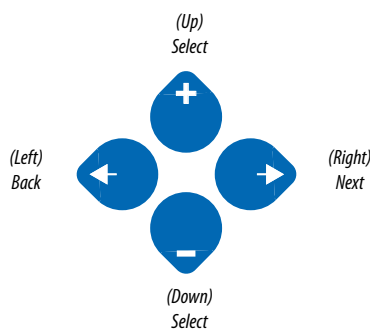
- Current interrupt capacity should be selected based on the installation category and fault current capability.
- Over-current protection should be selected with a time delay.
- The voltage rating should be sufficient for the input voltage applied.
- Provide overcurrent protection and disconnecting means to protect the wiring. For AC installations, use Veris AH02, AH03, AH04, or equivalent. For DC installations, external circuit protection must be provided. Suggested: 0.5 A, time delay fuses.
- The earth connection is required for electromagnetic compatibility (EMC) and is not a protective earth ground.

## DISPLAY SCREEN DIAGRAM

### LCD Screen:



### Buttons:



## QUICK SETUP INSTRUCTIONS

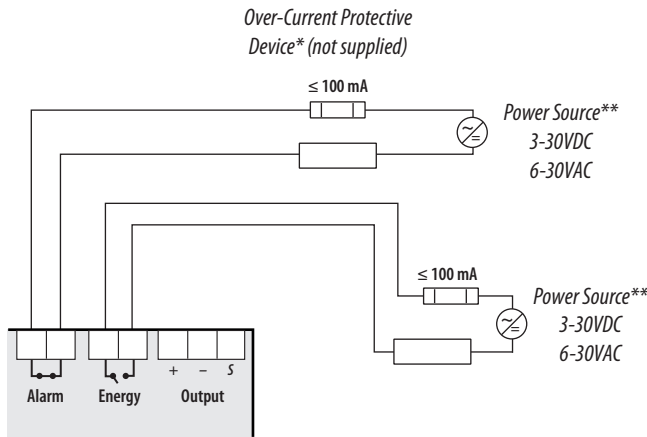
These instructions assume the meter is set to factory defaults. If it has been previously configured, all optional values should be checked.

- Press the **+** or **-** button repeatedly until **SETUP** screen appears.
- ▶** to the **PASSWD** screen.
- ▶** through the digits. Use the **+** or **-** buttons to select the password (the default is 00000). Exit the screen to the right.
- Use the **+** or **-** buttons to select the parameter to configure.
- If the unit has an RS-485 interface, the first Setup screen is **S COM** (set communications).
  - ▶** to the **ADDR** screen and through the address digits. Use the **+** or **-** buttons to select the Modbus address.
  - ▶** to the **BAUD** screen. Use the **+** or **-** buttons to select the baud rate.
  - ▶** to the **PAR** screen. Use the **+** or **-** buttons to select the parity.
  - ▶** back to the **S COM** screen.
- ▶** to the **S CT** (Set Current Transducer) screen. If this unit does not have an RS-485 port, this will be the first screen.
  - ▶** to the **CT V** screen. Use the **+** or **-** buttons to select the voltage mode Current Transducer output voltage.
  - ▶** to the **CT SZ** screen and through the digits. Use the **+** or **-** buttons to select the CT size in amps.
  - ▶** back to the **S CT** screen.
- ▶** to the **S SYS** (Set System) screen.
  - ▶** to the **SYSTEM** screen. Use the **+** or **-** buttons to select the System Type (see wiring diagrams).
  - ▶** back to the **S SYS** screen.
- (Optional) **▶** to the **S PT** (Set Potential Transformer) screen. If PTs are not used, then skip this step.
  - ▶** to the **PTRATIO** screen and through the digits. Use the **+** or **-** buttons to select the Potential Transformer step down ratio.
  - ▶** back to the **S PT** screen.
- ▶** to the **S V** (Set System Voltage) screen.
  - ▶** to the **VLL** (or **VLN** if system is 1L-1n) screen and through the digits. Use the **+** or **-** buttons to select the Line to Line System Voltage.
  - ▶** back to the **S V** screen.
- Use the **◀** to exit the setup screen and then **SETUP**.
- Check that the wrench is not displayed on the LCD.
  - If the wrench is displayed, use the **+** or **-** buttons to find the **FLERT** screen.
  - ▶** through the screens to see which alert is on.

For full setup instructions, see the configuration instructions on the following pages.

**SOLID-STATE PULSE OUTPUT**

The meter has one normally open (N.O.) KZ Form A output and one normally closed (N.C.) KY solid-state output.\*\*\* One is dedicated to import energy (Wh), and the other to Alarm. See the Setup section for configuration information.



The solid state pulse outputs are rated for 30VAC/DC nom.

Maximum load current is 100mA at 25°C. Derate 0.56mA per °C above 25°C.

\* The over-current protective device must be rated for the short circuit current at the connection point.

\*\* All pulse outputs and communication circuits are only intended to be connected to non-hazardous voltage circuits (SELV or Class 2). Do not connect to hazardous voltages.

\*\*\* While the relay used for the Phase Loss contact is Normally Closed (contacts are closed when the meter is not powered), closure indicates the presence of an alarm; either loss of phase, when the meter is powered, or loss of power when the meter is not. The contacts are open when the meter is powered and no phase loss alarm conditions are present.

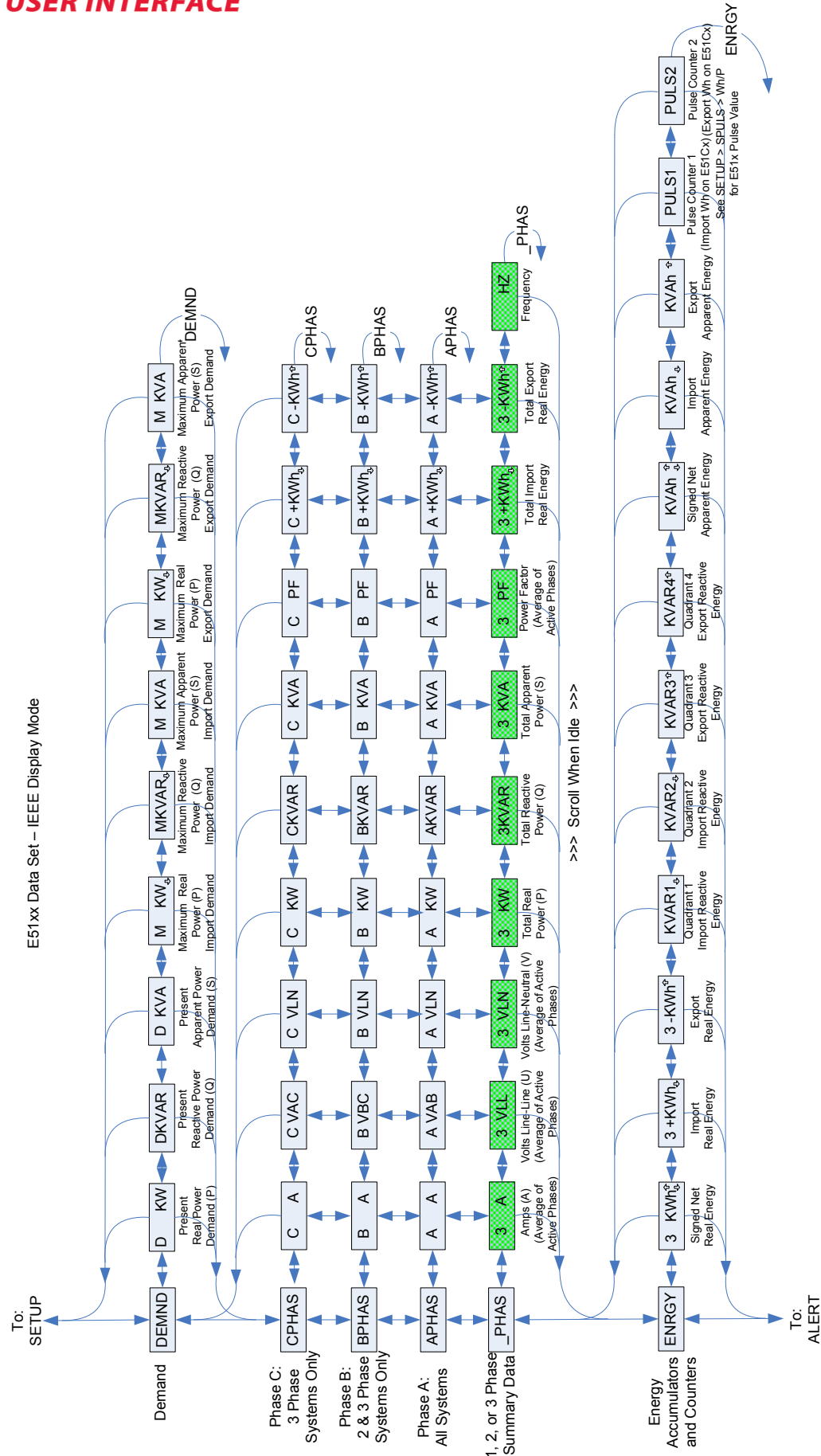
**UI MENU ABBREVIATIONS DEFINED**

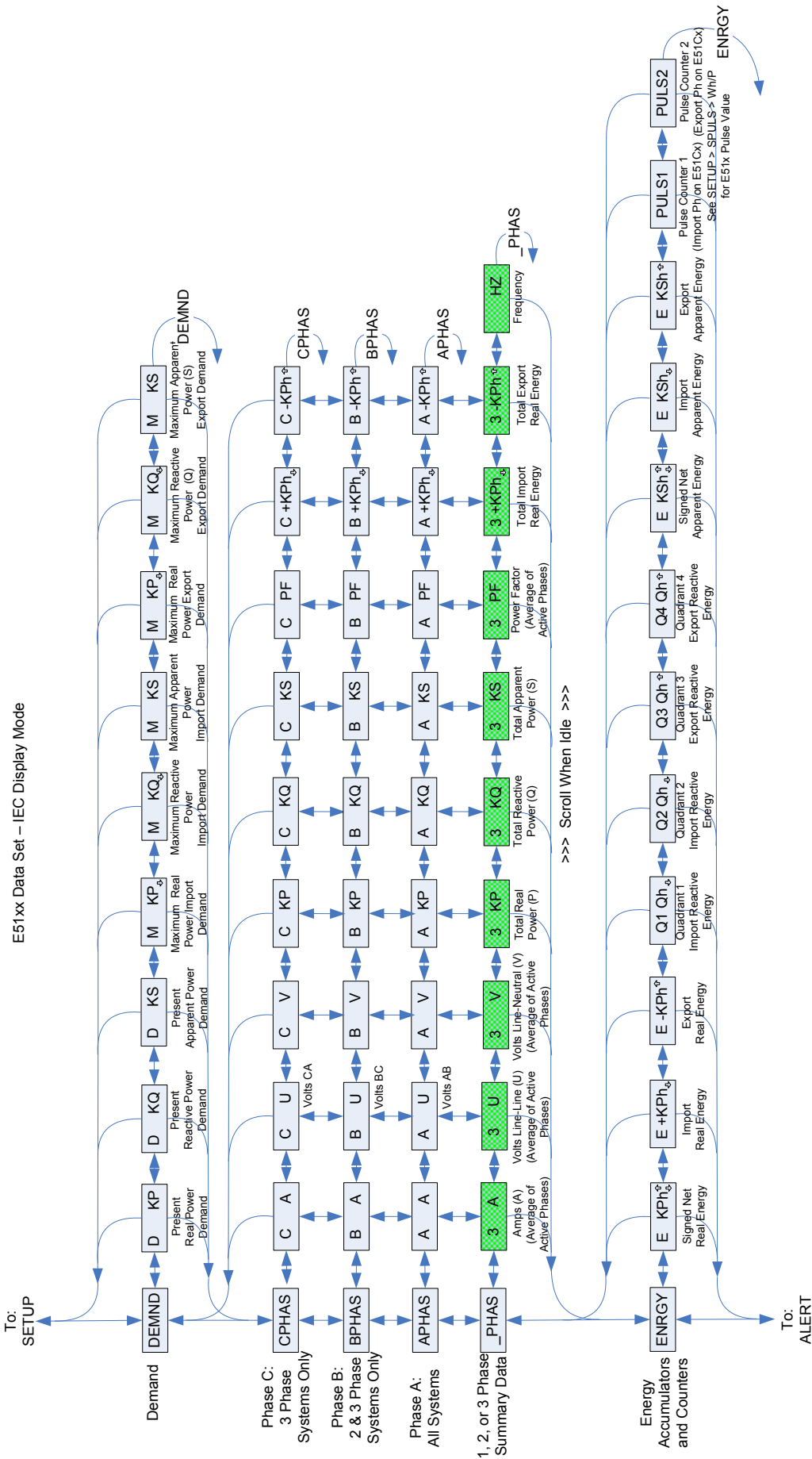
The user can set the display mode to IEC or IEEE notation in the SETUP menu.

Main Menu		
IEC	IEEE	Description
D	D	Demand
MAX	M	Maximum Demand
P	W	Present Real Power
Q	VAR	Present Reactive Power
S	VA	Present Apparent Power
A	A	Amps
UAB, UBC, UAC	VAB, VBC, VAC	Voltage Line to Line
V	VLN	Voltage Line to Neutral
PF	PF	Power Factor
U	VLL	Voltage Line to Line
HZ	HZ	Frequency
KSh	KVAh	Accumulated Apparent Energy
KQh	KVARh	Accumulated Reactive Energy
KPh	KWh	Accumulated Real Energy
PLOSS	PLOSS	Phase Loss
LOWPF	LOWPF	Low Power Factor Error
F ERR	F ERR	Frequency Error
I OVR	I OVR	Over Current
V OVR	V OVR	Over Voltage
PULSE	PULSE	kWh Pulse Output Overrun (configuration error)
_PHASE	_PHASE	Summary Data for 1, 2, or 3 active phases
ALERT	ALERT	Diagnostic Alert Status
INFO	INFO	Unit Information
MODEL	MODEL	Model Number
OS	OS	Operating System
RS	RS	Reset System
SN	SN	Serial Number
RESET	RESET	Reset Data
PASWD	PASWD	Enter Reset or Setup Password
ENERG	ENERG	Reset Energy Accumulators
DEMND	DEMND	Reset Demand Maximums
⇧		Import
⇩		Export
PULS_	PULS_	Pulse Counter (if equipped)
Q_	Q_	Quadrant 1-4 per IEEE 1459
n	n	Net

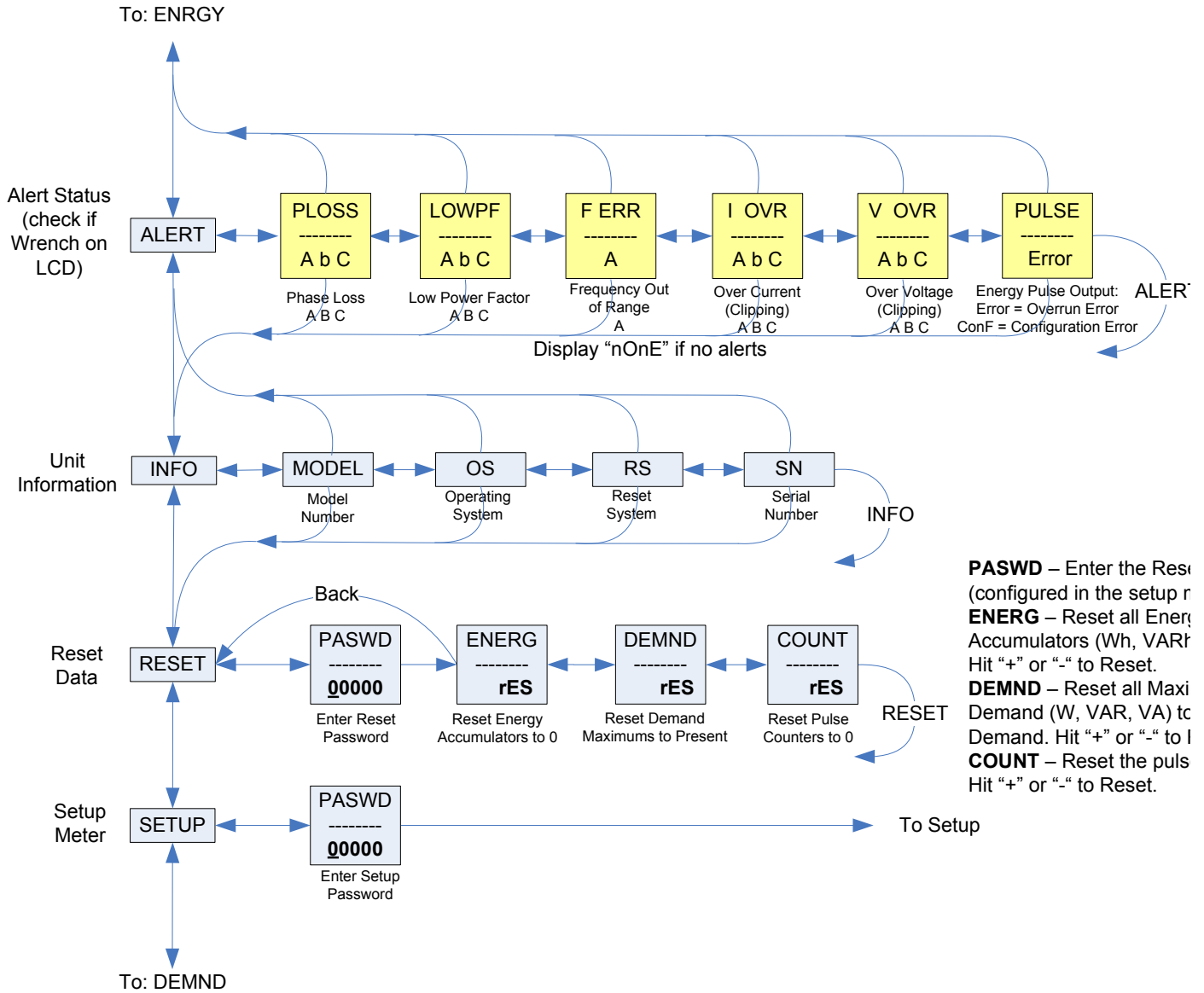


**USER INTERFACE**





**ALERT/RESET INFORMATION**



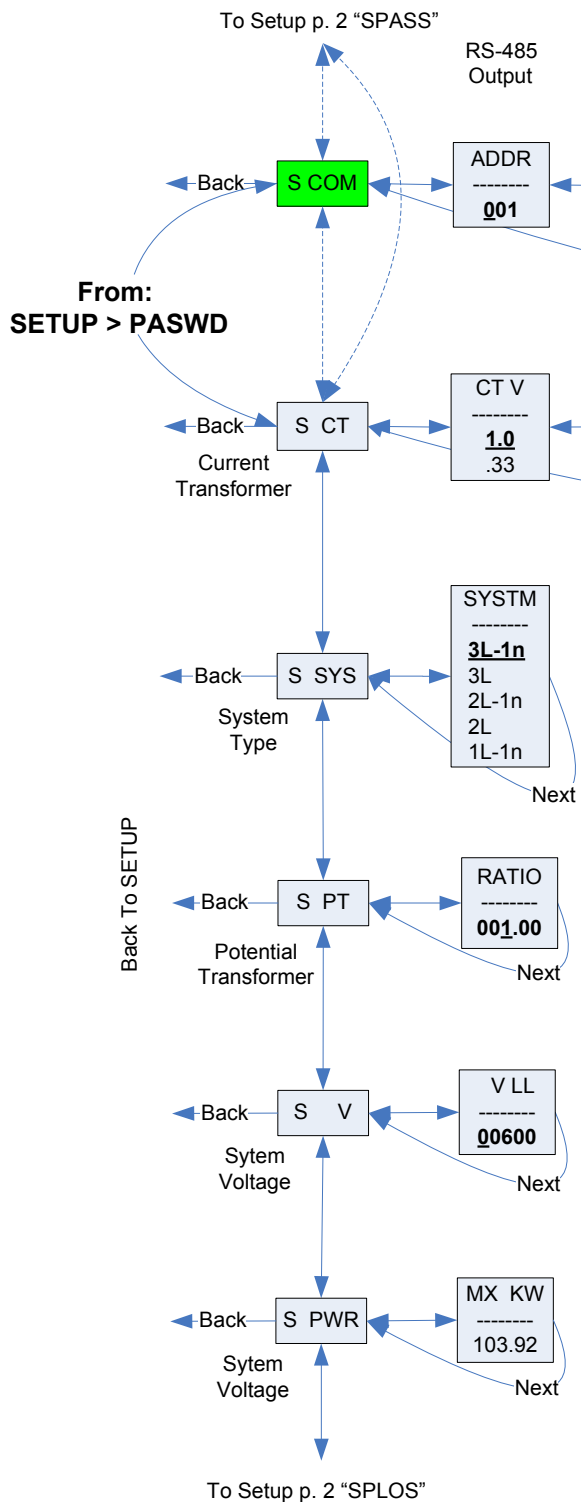
**PASWD** – Enter the Reset Password (configured in the setup menu)

**ENERG** – Reset all Energy Accumulators (Wh, VAR, VA) to 0. Hit “+” or “-” to Reset.

**DEMND** – Reset all Maximum Demand (W, VAR, VA) to Present. Hit “+” or “-” to Reset.

**COUNT** – Reset the pulse counters to 0. Hit “+” or “-” to Reset.

**USER INTERFACE FOR SETUP**



**Set Communications Parameters:**

**ADDR - Modbus Address:** 1 – 247.  
 + increments the selected (blinking) digit.  
 - selects the digit to the left.  
**BAUD - Baud Rate:** 1200 – 38400 Baud  
**PAR - Parity:** Odd, Even, None  
 + or – to step through the options.

**Set Current Transducer:**

**CT V - CT Input Voltage:** + or – to Select 1.0 or .33V.  
**CT SZ - CT Size:** in Amps. Maximum is 32000 Amps.

**Set System Configuration:**

**SYSTEM:** + or – to step through the following System Type options:

System	Reg 130	CTs	Description
<b>3L-1n</b>	40	3	Wye Three Phase: A, B, & C with Neutral (Default).
3L	31	3	Delta Three Phase: A, B & C; no Neutral
2L-1n	12	2	Single Split Phase: A & B with Neutral
2L	11	1	Single Phase: A & B; no Neutral
1L-1n	10	1	Single Phase: A to Neutral

**Set Potential Transformer Ratio:**

**RATIO** – Potential transformer step down is RATIO:1. Default is 1:1 (No PT installed). See Install for wiring diagrams. This value must be set before the System Voltage (if used).

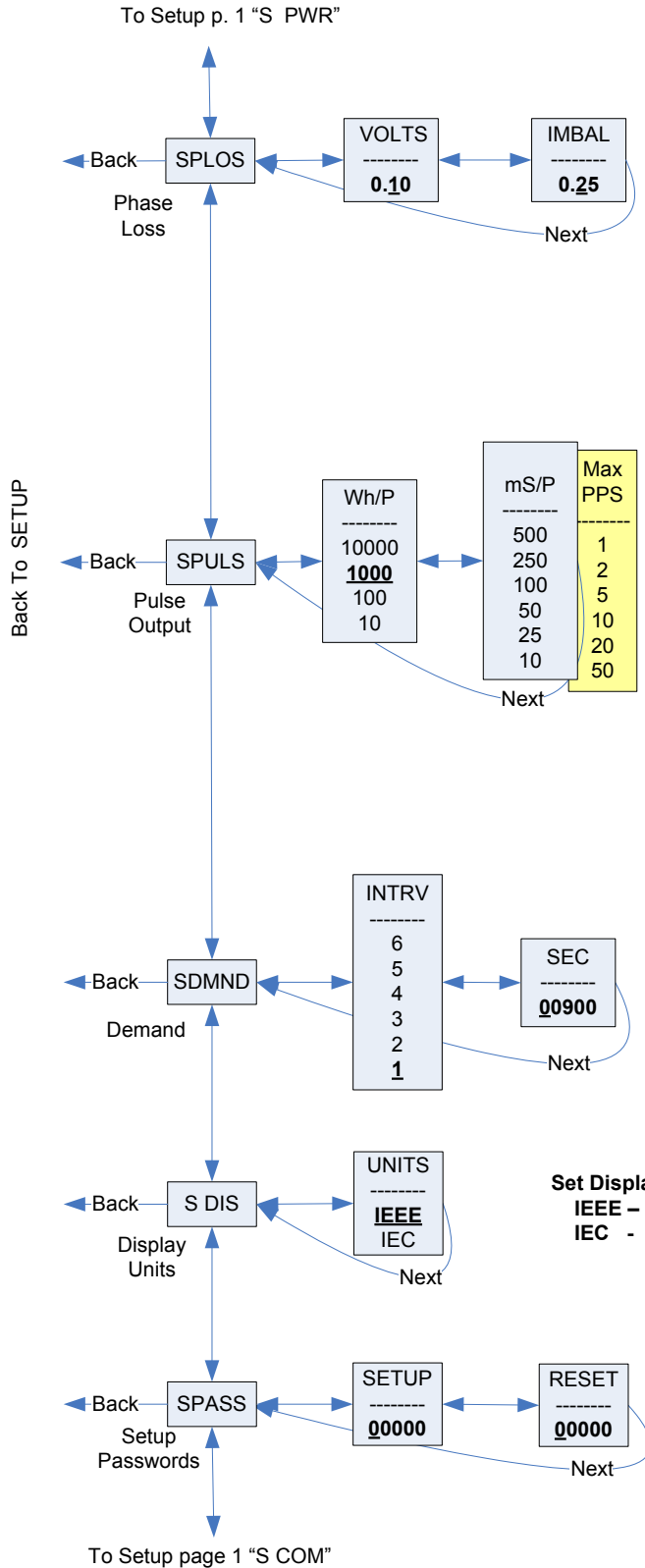
**Set System Voltage:**

**V LL** – The nominal Line to Line Voltage for the system. This is used by the meter to calculate the theoretical maximum system power, and as the reference voltage for setting the Phase Loss threshold. Maximum is 32000 Volts. For system type 1+N (10), this is a Line to Neutral Voltage, indicated by "V LN". Note: the meter will reject settings that are not within the meter's operating range when divided by the PT ratio.

**System Power:**

**MX KW** – The theoretical Maximum System Power is calculated by the meter from the System Voltage, CT size, and System Type. Power Factor is assumed to be unity. The value of System Power is used to determine which combinations of pulse weight and duration are valid and will keep up with the maximum power the meter will see. This value is read only.

Note: **Bold** is the Default.



**Set Phase Loss:**

**VOLTS - Phase Loss Voltage:** The fraction of the system voltage below which Phase Loss Alarm is on. For system types with neutral, the Line to Neutral voltage is also calculated and tested. If the System Voltage is 600 and the fraction is set to 0.10, then the Phase Loss threshold will be 60 volts.

**IMBAL - Phase Loss Imbalance:** The fractional difference in Line to Line voltages above which Phase Loss Alarm is on. For system types with neutral, the Line to Neutral voltages are also tested. For system types 1+N (10) and 2 (11), imbalance is not tested.

**Set Pulse:**

The System Type, CT size, PT Ratio, and System Voltage must all be configured before setting the Pulse Energy. If any of these parameters are changed, the meter will hunt for a new Pulse Duration, but will not change the Pulse Energy. If it cannot find a solution, the meter will display the wrench, show "ConF" in the ALARM -> PULSE screen, and enable Energy pulse output configuration error bit in the Modbus Diagnostic Alert Bitmap (if equipped).

**Wh/P - Set Pulse Energy:** In Watt Hours (& VAR Hours, if present) per Pulse. When moving down to a smaller energy, the meter will not allow the selection if it cannot find a pulse duration that will allow the pulse output to keep up with Theoretical Maximum System Power (see S\_PWR screen). When moving up to a larger energy, the meter will jump to the first value where it can find a valid solution.

**mS/P - Minimum Pulse Duration Time:** This read only value is set by the meter to the slowest duration (in mS per closure) that will keep up with the Theoretical Maximum System Power. The open time is greater than or equal to the closure time. The maximum Pulses Per Second (PPS) is shown in yellow.

**Set Demand Interval:**

**INTRV -** The number of Sub-Intervals (1 to 6) in a Demand Interval. Default is 1 (block demand).

**SEC -** Sub-Interval length in seconds. Default is 900 (15 minutes). Set to 0 for external sync-to-comms (Modbus units only).

**Set Display Units: +/- to switch between:**

**IEEE -** VLL VLN W VAR VA Units.

**IEC -** U V P Q S Units.

**Set Passwords:**

**SETUP -** The Password to enter the SETUP menu.

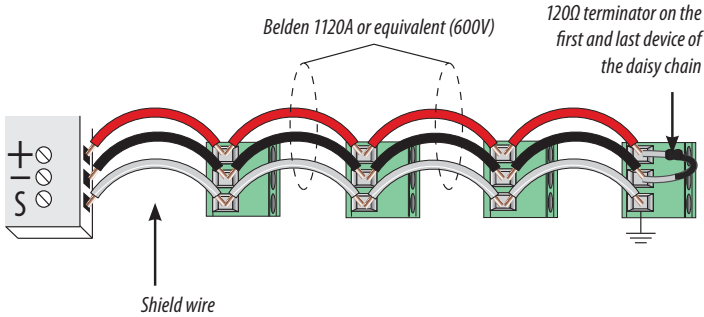
**RESET -** The Password to enter the RESET menu.

Back To SETUP

**RS-485 COMMUNICATIONS**

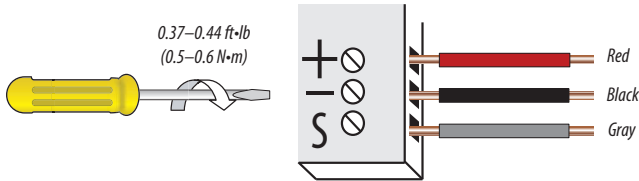
**Daisy-chaining Devices to the Power Meter**

The RS-485 slave port allows the power meter to be connected in a daisy chain with up to 63 2-wire devices. In this bulletin, communications link refers to a chain of devices that are connected by a communications cable.



**NOTES:**

- The terminal's voltage and current ratings are compliant with the requirements of the EIA RS-485 communications standard.
- The RS-485 transceivers are ¼ unit load or less.
- RS-485+ has a 47 kOhm pull up to +5V, and RS-485- has a 47 kOhm pull down to Shield (RS-485 signal ground).
- Wire the RS-485 bus as a daisy chain from device to device, without any stubs. Use 120 ohm termination resistors (Veris AH22 or equivalent) at each end of the bus (not included).
- Shield is not internally connected to Earth Ground.
- Connect Shield to Earth Ground somewhere on the RS-485 bus.
- When tightening terminals, ensure that the correct torque is applied: 0.37-0.44 ft-lb (0.5-0.6 N·m).



## DATA LOGGING (E51C3 ONLY)

The E51C3 includes a data logging feature that records 10 meter parameters, each in its own buffer.

### Configuration.

Use register 150 to set the data logging time subinterval. Writing to the storage buffer is triggered by the subinterval timer. The default subinterval is 15 minutes (at a 15 minute interval setting, the buffers hold 60 days of data). An external timer can be used over Modbus by setting this register to 0.

Use register 159 to turn on data logging and select either Single Shot or Continuous mode. (default is data logging on, Continuous mode). In Single Shot mode, the meter records data until the buffer is full. When the buffer is full, the meter stops recording new readings. Data for this time period is kept, but newer energy information is lost. In Continuous mode, the meter continues to record energy data as long as the meter is operating. The buffer can only hold 5760 entries at one time, however, so when the number of records exceeds 5760, the oldest entry is deleted to make room for the newest.

Registers 169-178 contain the pointers to 10 data storage buffers. Each buffer is user-configurable with the Modbus address of the 16-bit data output to be stored. 32-bit data, such as floating point data or 32-bit integer energy accumulators, require two buffers. However, the lower 16 bits of an integer energy accumulator can be stored in a single buffer (optional).

When the E51C3 is first installed, the buffers contain QNAN data, with a value of 0x8000. This data is considered invalid. If the buffer is reset at any point, all entries in the buffers are overwritten with this 0x8000 value, indicating that it is invalid. All invalid data is overwritten as the meter fills the buffer with new data entries.

### Reading Data.

Use register 158 to choose which buffer to read. When this register value is set to 0, the meter is in data logging mode. Changing this value from 0 to (1 through 10) switches the meter to reading mode and selects a buffer to read. Data from the selected buffer appears in registers 8000 to 13760.

### Read/Write Collision.

If the demand sub-interval timeout occurs while the user is reading a page (register 158  $\neq$  0), the log data will be held in RAM until the next demand subinterval. At that time, both the saved data from the previous cycle and the new data will be written to the log, whether the page register has been set back to 0 or not. Error bits in the Log Status Register (160) track these conditions. Subsequent log writes will proceed normally. Provided the log read is concluded in less time than the demand sub-interval, this mechanism handles the occasional collision and prevents the user from reading data as the buffer is being updated.

The Log Status Register has additional error flag bits that indicate whether logging has been reset or interrupted (power cycle, etc.) during the previous demand sub-interval, and whether the Real-Time Clock has been changed (re-initialized to default date/time due to a power-cycle or modified via Modbus commands).

## STANDARD MODBUS DEFAULT SETTINGS

Setting	Value	Modbus Register
Setup Password	00000	–
Reset Password	00000	–
System Type	40 (3 + N) Wye	130
CT Primary Ratio (if CTs are not included)	100A	131
CT Secondary Ratio	1V	132
PT Ratio	1:1 (none)	133
System Voltage	600 V L-L	134
Max. Theoretical Power (Analog Output: full scale (20mA or 5V))	104 kW	135
Display Mode	1 (IEEE units)	137
Phase Loss	10% of System Voltage (60V), 25% Phase to Phase Imbalance	142, 143
Pulse Energy	1 (kWh/pulse)	144
Demand: number of sub-intervals per interval	1 (block mode)	149
Demand: sub-interval length	900 sec (15 min)	150
Modbus Address	001	–
Modbus Baud Rate	19200 baud	–
Modbus Parity	None	–
Log Read Page	0	158
Logging Configuration Register	0	159
Log Register Pointer 1	3 (Import Real Energy MSR)	169
Log Register Pointer 2	4 (Import Real Energy LSR)	170
Log Register Pointer 3	5 (Export Real Energy MSR)	171
Log Register Pointer 4	6 (Export Real Energy LSR)	172
Log Register Pointer 5	29 (Real Demand)	173
Log Register Pointer 6	30 (Reactive Demand)	174
Log Register Pointer 7	31 (Apparent Demand)	175
Log Register Pointer 8	155 (Month/Day)	176
Log Register Pointer 9	156 (Year/Hour)	177
Log Register Pointer 10	157 (Minutes/Seconds)	178

**MODBUS POINT MAP**

The E51C2 Full Data Set (FDS) model features data outputs such as demand calculations, per phase signed watts VA and VAR, import/export Wh and VAh, and VARh accumulators by quadrant. The E51C3 Data Logging model includes the FDS and adds log configuration registers 155-178 and log buffer reading at registers 8000-13760. The meter supports variable CTs and PTs, allowing a much wider range of operation from 90V x 5A up to 32000V x 32000A. To promote this, the meter permits variable scaling of the 16-bit integer registers via the scale registers. The 32-bit floating point registers do not need to be scaled.

Integer registers begin at 001 (0x001). Floats at 257 (0x101). Configuration registers at 129 (0x081). Values not supported in a particular System Type configuration will report QNAN (0x8000 in Integer Registers, 0x7FC00000 in Floating Point Registers). Register addresses are in PLC style base 1 notation. Subtract 1 from all addresses for the base 0 value used on the Modbus RS-485 link.

**Supported Modbus Commands**

*Note: ID String information varies from model to model. Text shown here is an example.*

Command	Description
0x03	Read Holding Registers
0x04	Read Input Registers
0x06	Preset Single Register
0x10	Preset Multiple Registers
0x11	Report ID
	Return string: byte0: address byte1: 0x11 byte2: #bytes following w/out crc byte3: ID byte = 247 byte4: status = 0xFF if the operating system is used; status = 0x00 if the reset system is used bytes5+: ID string = "Veris Industries E51xx Power Meter Full Data Set" or "Veris Industries E51xx Power Meter - RESET SYSTEM RUNNING RS Version x.xxx" last 2 bytes: CRC
0x2B	Read Device Identification, BASIC implementation (0x00, 0x01 and 0x02 data), Conformity Level 1.
	Object values: 0x01: "Veris Industries" 0x02: " E51xx" 0x03: "Vxx.yyy", where xx.yyy is the OS version number (reformatted version of the Modbus register #7001, (Firmware Version, Operating System). If register #7001 == 12345, then the 0x03 data would be "V12.345").

**Legend**

The following table lists the addresses assigned to each data point. For floating point format variables, each data point appears twice because two 16-bit addresses are required to hold a 32-bit float value. Negative signed integers are 2's complement.

R/W	R=read only R/W=read from either int or float formats, write only to integer format.
NV	Value is stored in non-volatile memory. The value will still be available if the meter experiences a power loss and reset.
Format	UInt    Unsigned 16-bit integer.
	SInt    Signed 16-bit integer.
	ULong   Unsigned 32-bit integer; Upper 16-bits (MSR) in lowest-numbered / first listed register (001/002 = MSR/LSR).
	SLong   Signed 32-bit integer; Upper 16-bits (MSR) in lowest-numbered / first listed register (001/002 = MSR/LSR).
Float	32-bit floating point; Upper 16-bits (MSR) in lowest-numbered / first listed register (257/258 = MSR/LSR). Encoding is per IEEE standard 754 single precision.
Units	Lists the physical units that a register holds.
Scale Factor	Some Integer values must be multiplied by a constant scale factor (typically a fraction), to be read correctly. This is done to allow integer numbers to represent fractional numbers.
Range	Defines the limit of the values that a register can contain.

**SunSpec Alliance Interoperability Specification Compliance**

This meter implements the draft SunSpec 1.0 common elements starting at base 1 address 40001, and the proposed SunSpec 1.1 meter model at 40070 (these addresses are not in Modicon notation). See [www.veris.com](http://www.veris.com) or [www.sunspec.org](http://www.sunspec.org) for copies of these specifications.



*The SunSpec Alliance logo is a trademark or registered trademark of the SunSpec Alliance.*



E51C2 FDS	E51C3 Log	Register	R/W	NV	Format	Units	Scale	Range	Description		
Integer Data: Summary of Active Phases											
. .	001	R	NV	SLong	kWh	E	-2147483647 to +2147483647	Real Energy: Net (Import - Export)	MSR	Accumulated Real Energy (Ph)	Clear via reset register 129
. .	002								LSR		
. .	003	R	NV	ULong	kWh	E	0 to 0xFFFFFFFF	Real Energy: Quadrants 1 & 4 Import	MSR		
. .	004								LSR		
. .	005	R	NV	ULong	kWh	E	0 to 0xFFFFFFFF	Real Energy: Quadrants 2 & 3 Export	MSR		
. .	006								LSR		
. .	007	R	NV	ULong	kVARh	E	0 to 0xFFFFFFFF	Reactive Energy - Quadrant 1: Lags Import Real Energy (IEC) Inductive (IEEE)	MSR	Accumulated Reactive Energy (Qh): Quadrants 1 + 2 = Import Quadrants 3 + 4 = Export	
. .	008								LSR		
. .	009	R	NV	ULong	kVARh	E	0 to 0xFFFFFFFF	Reactive Energy - Quadrant 2: Leads Export Real Energy (IEC) Inductive (IEEE)	MSR		
. .	010								LSR		
. .	011	R	NV	ULong	kVARh	E	0 to 0xFFFFFFFF	Reactive Energy - Quadrant 3: Lags Export Real Energy (IEC) Capacitive (IEEE)	MSR		
. .	012								LSR		
. .	013	R	NV	ULong	kVARh	E	0 to 0xFFFFFFFF	Reactive Energy - Quadrant 4: Leads Import Real Energy (IEC) Capacitive (IEEE)	MSR	Accumulated Apparent Energy (Sh): Import and Export correspond with Real Energy	
. .	014								LSR		
. .	015	R	NV	SLong	kVAh	E	-2147483647 to +2147483647	Apparent Energy: Net (Import - Export)	MSR		
. .	016								LSR		
. .	017	R	NV	ULong	kVAh	E	0 to 0xFFFFFFFF	Apparent: Quadrants 1 & 4 Import	MSR		
. .	018								LSR		
. .	019	R	NV	ULong	kVAh	E	0 to 0xFFFFFFFF	Apparent: Quadrants 2 & 3 Export	MSR		
. .	020								LSR		
. .	021	R		SInt	kW	W	-32767 to +32767	Total Instantaneous Real (P) Power			
. .	022	R		SInt	kVAR	W	0 to 32767	Total Instantaneous Reactive (Q) Power			
. .	023	R		UInt	kVA	W	0 to 32767	Total Instantaneous Apparent (S) Power (vector sum)			
. .	024	R		SInt	Ratio	0.0001	-10000 to +10000	Total Power Factor (total kW / total kVA)			
. .	025	R		UInt	Volt	V	0 to 32767	Voltage, L-L (U), average of active phases			
. .	026	R		UInt	Volt	V	0 to 32767	Voltage, L-N (V), average of active phases			
. .	027	R		UInt	Amp	I	0 to 32767	Current, average of active phases			
. .	028			UInt	Hz	0.01	4500 to 6500	Frequency			
. .	029	R		SInt	kW	W	-32767 to +32767	Total Real Power Present Demand			
. .	030			SInt	kVAR	W	-32767 to +32767	Total Reactive Power Present Demand			
. .	031	R		SInt	kVA	W	-32767 to +32767	Total Apparent Power Present Demand			
. .	032	R	NV	SInt	kW	W	-32767 to +32767	Total Real Power Max. Demand	Import	Reset via register 129	
. .	033	R	NV	SInt	kVAR	W	-32767 to +32767	Total Reactive Power Max. Demand			
. .	034	R	NV	SInt	kVA	W	-32767 to +32767	Total Apparent Power Max. Demand			
. .	035	R	NV	SInt	kW	W	-32767 to +32767	Total Real Power Max. Demand	Export		
. .	036	R	NV	SInt	kVAR	W	-32767 to +32767	Total Reactive Power Max. Demand			
. .	037	R	NV	SInt	kVA	W	-32767 to +32767	Total Apparent Power Max. Demand			
. .	038	R		UInt				Reserved, returns 0x8000 (QNaN)			
. .	039	R	NV	ULong			0 to 0xFFFFFFFF	Pulse Counter 1 (Import Real Energy)	MSR	Contact Closure Counters. Valid for both pulse inputs and outputs. E51Cx counts are shown in (). See register 144 - Energy Per Pulse for the Wh per pulse count.	
. .	040								LSR		
. .	041	R	NV	ULong			0 to 0xFFFFFFFF	Pulse Counter 2 (Export Real Energy)	MSR		
. .	042								LSR		

E51C2 FDS	E51C3 Log	Register	R/W	NV	Format	Units	Scale	Range	Description			
Integer Data: Per Phase												
. .	043	R	NV	ULong	kWh	E	0 to 0xFFFFFFFF	Accumulated Real Energy, Phase A	MSR	Import	Accumulated Real Energy (Ph), per phase	
. .	044								LSR			
. .	045	R	NV	ULong	kWh	E	0 to 0xFFFFFFFF	Accumulated Real Energy, Phase B	MSR			
. .	046								LSR			
. .	047	R	NV	ULong	kWh	E	0 to 0xFFFFFFFF	Accumulated Real Energy, Phase C	MSR			
. .	048								LSR			
. .	049	R	NV	ULong	kWh	E	0 to 0xFFFFFFFF	Accumulated Real Energy, Phase A	MSR	Export		
. .	050								LSR			
. .	051	R	NV	ULong	kWh	E	0 to 0xFFFFFFFF	Accumulated Real Energy, Phase B	MSR			
. .	052								LSR			
. .	053	R	NV	ULong	kWh	E	0 to 0xFFFFFFFF	Accumulated Real Energy, Phase C	MSR			
. .	054								LSR			
. .	055	R	NV	ULong	kVARh	E	0 to 0xFFFFFFFF	Accumulated Q1 Reactive Energy, Phase A	MSR	Import	Accumulated Reactive Energy (Qh), Per Phase	
. .	056								LSR			
. .	057	R	NV	ULong	kVARh	E	0 to 0xFFFFFFFF	Accumulated Q1 Reactive Energy, Phase B	MSR			
. .	058								LSR			
. .	059	R	NV	ULong	kVARh	E	0 to 0xFFFFFFFF	Accumulated Q1 Reactive Energy, Phase C	MSR			
. .	060								LSR			
. .	061	R	NV	ULong	kVARh	E	0 to 0xFFFFFFFF	Accumulated Q2 Reactive Energy, Phase A	MSR			
. .	062								LSR			
. .	063	R	NV	ULong	kVARh	E	0 to 0xFFFFFFFF	Accumulated Q2 Reactive Energy, Phase B	MSR			
. .	064								LSR			
. .	065	R	NV	ULong	kVARh	E	0 to 0xFFFFFFFF	Accumulated Q2 Reactive Energy, Phase C	MSR			
. .	066								LSR			
. .	067	R	NV	ULong	kVARh	E	0 to 0xFFFFFFFF	Accumulated Q3 Reactive Energy, Phase A	MSR	Export		
. .	068								LSR			
. .	069	R	NV	ULong	kVARh	E	0 to 0xFFFFFFFF	Accumulated Q3 Reactive Energy, Phase B	MSR			
. .	070								LSR			
. .	071	R	NV	ULong	kVARh	E	0 to 0xFFFFFFFF	Accumulated Q3 Reactive Energy, Phase C	MSR			
. .	072								LSR			
. .	073	R	NV	ULong	kVARh	E	0 to 0xFFFFFFFF	Accumulated Q4 Reactive Energy, Phase A	MSR			
. .	074								LSR			
. .	075	R	NV	ULong	kVARh	E	0 to 0xFFFFFFFF	Accumulated Q4 Reactive Energy, Phase B	MSR			
. .	076								LSR			
. .	077	R	NV	ULong	kVARh	E	0 to 0xFFFFFFFF	Accumulated Q4 Reactive Energy, Phase C	MSR			
. .	078								LSR			

E51C2 FDS	E51C3 Log	Register	R/W	NV	Format	Units	Scale	Range	Description				
• •	•	079	R	NV	ULong	kVAh	E	0 to 0xFFFFFFFF	Accumulated Apparent Energy, Phase A	MSR	Import	Accumulated Apparent Energy (Sh), Per Phase	
		080								LSR			
• •	•	081	R	NV	ULong	kVAh	E	0 to 0xFFFFFFFF	Accumulated Apparent Energy, Phase B	MSR			
		082								LSR			
• •	•	083	R	NV	ULong	kVAh	E	0 to 0xFFFFFFFF	Accumulated Apparent Energy, Phase C	MSR			
		084								LSR			
• •	•	085	R	NV	ULong	kVAh	E	0 to 0xFFFFFFFF	Accumulated Apparent Energy, Phase A	MSR			Export
		086								LSR			
• •	•	087	R	NV	ULong	kVAh	E	0 to 0xFFFFFFFF	Accumulated Apparent Energy, Phase B	MSR			
		088								LSR			
• •	•	089	R	NV	ULong	kVAh	E	0 to 0xFFFFFFFF	Accumulated Apparent Energy, Phase C	MSR			
		090								LSR			
• •	•	091	R		SInt	kW	W	-32767 to +32767	Real Power (P), Phase A		Real Power (P)		
• •	•	092	R		SInt	kW	W	-32767 to +32767	Real Power (P), Phase B				
• •	•	093	R		SInt	kW	W	-32767 to +32767	Real Power (P), Phase C				
• •	•	094	R		SInt	kVAR	W	-32767 to +32767	Reactive Power (Q), Phase A		Reactive Power (Q)		
• •	•	095	R		SInt	kVAR	W	-32767 to +32767	Reactive Power (Q), Phase B				
• •	•	096	R		SInt	kVAR	W	-32767 to +32767	Reactive Power (Q), Phase C				
• •	•	097	R		UInt	kVA	W	0 to 32767	Apparent Power (S), Phase A		Apparent Power (S)		
• •	•	098	R		UInt	kVA	W	0 to 32767	Apparent Power (S), Phase B				
• •	•	099	R		UInt	kVA	W	0 to 32767	Apparent Power (S), Phase C				
• •	•	100	R		SInt	Ratio	0.0001	-10000 to +10000	Power Factor (PF), Phase A		Power Factor (PF)		
• •	•	101	R		SInt	Ratio	0.0001	-10000 to +10000	Power Factor (PF), Phase B				
• •	•	102	R		SInt	Ratio	0.0001	-10000 to +10000	Power Factor (PF), Phase C				
• •	•	103	R		UInt	Volt	V	0 to 32767	Voltage (U), Phase A-B		Line to Line Voltage (U)		
• •	•	104	R		UInt	Volt	V	0 to 32767	Voltage (U), Phase B-C				
• •	•	105	R		UInt	Volt	V	0 to 32767	Voltage (U), Phase A-C				
• •	•	106	R		UInt	Volt	V	0 to 32767	Voltage (V), Phase A-N		Line to Neutral Voltage (V)		
• •	•	107	R		UInt	Volt	V	0 to 32767	Voltage (V), Phase B-N				
• •	•	108	R		UInt	Volt	V	0 to 32767	Voltage (V), Phase C-N				
• •	•	109	R		UInt	Amp	I	0 to 32767	Current, Phase A		Current		
• •	•	110	R		UInt	Amp	I	0 to 32767	Current, Phase B				
• •	•	111	R		UInt	Amp	I	0 to 32767	Current, Phase C				
• •	•	112	R		UInt				Reserved, Returns 0x8000 (QNaN)				

E51C2 FDS	E51C3 Log	Register	R/W	NV	Format	Units	Scale	Range	Description
Configuration									
•	•	129	R/W		UInt			N/A	Reset: - Write 30078 (0x757E) to clear all Energy Accumulators to 0 (All). - Write 21211 (0x52DB) to begin new Demand Sub-Interval calculation cycle. Takes effect at the end of the next 1 second calculation cycle. Write no more frequently than every 10 seconds. - Write 21212 (0x52DC) to reset Max Demand values to Present Demand Values. Takes effect at the end of the next 1 second calculation cycle. Write no more frequently than every 10 seconds. - Write 16640 (0x4100) to reset Logging (E51C3 only). - Write 16498 (0x4072) to clear Pulse Counts to zero. - Read always returns 0.
•	•	130	R/W	NV	UInt			10, 11, 12, 31, 40	Single Phase: A + N Single Phase: A + B Single Split Phase: A + B + N 3 phase Δ, A + B + C, no N 3 phase Y, A + B + C + N System Type (See Manual. Note: only the indicated phases are monitored for Phase Loss)
•	•	131	R/W	NV	UInt	Amps		1-32000	CT Ratio – Primary
•	•	132	R/W	NV	UInt			1, 3	CT Ratio – Secondary Interface (1 or 1/3 V, may not be user configurable)
•	•	133	R/W	NV	UInt		100	0.01-320.00	PT Ratio: The meter scales this value by 100 (i.e. entering 200 yields a potential transformer ratio of 2:1). The default is 100 (1.00:1), which is with no PT attached. Set this value before setting the system voltage (below)
•	•	134	R/W	NV	UInt			82-32000	System Voltage: This voltage is line to line, unless in system type 10 (register 130), which is line to neutral. The meter uses this value to calculate the full scale power for the pulse configuration (below), and as full scale for phase loss (register 142). The meter will refuse voltages that are outside the range of 82-660 volts when divided by the PT Ratio (above).
•	•	135	R	NV	UInt	kW	W	1-32767	Theoretical Maximum System Power – This read only register is the theoretical maximum power the meter expects to see on a service. It is calculated by the meter from the System Type (register 130), CT size (register 131), and System Voltage (register 134) and is updated whenever the user changes any of these parameters. It is used to determine the maximum power the pulse outputs can keep up with. This integer register has the same scale as other integer power registers (see register 140 for power scaling).
•	•	136	R		UInt				Reserved, always returns 0
•	•	137	R/W	NV	UInt			0,1	Display Units: 0 = IEC (U, V, P, Q, S), 1 = IEEE (default: VLL, VLN, W, VAR, VA)
•	•	138	R		SInt			-4 0.0001 -3 0.001	Scale Factor I (Current)
•	•	139	R		SInt			-2 0.01 -1 0.1	Scale Factor V (Voltage)
•	•	140	R		SInt			0 1.0 1 10.0 2 100.0	Scale Factor W (Power)
•	•	141	R		SInt			3 1000.0 4 10000.0	Scale Factor E (Energy)
•	•	142	R/W	NV	UInt	%		1-99	Phase Loss Voltage Threshold in percent of system voltage (register 134). Default value is 10 (%). Any phase (as configured in register 130) whose level drops below this threshold triggers a Phase Loss alert, i.e., if the System voltage is set to 480 V L-L, the L-N voltage for each phase should be 277 V. When the threshold is set to 10%, if any phase drops more than 10% below 277 V, (less than 249 V), or if any L-L voltage drops more than 10% below 480 V (less than 432 V) the corresponding phase loss alarm bit in register 146 will be true.
•	•	143	R/W	NV	UInt	%		1-99	Phase Loss Imbalance Threshold in Percent. Default is 25% phase to phase difference. For a 3-phase Y (3 + N) system type (40 in register 130), both Line to Neutral and Line to Line voltages are tested. In a 3-phase Δ System type (31 in register 130), only Line to Line voltages are examined. In a single split-phase (2 + N) system type (12 in register 130), just the line to neutral voltage are compared.

E51C2 FDS	E51C3 Log	Register	R/W	NV	Format	Units	Scale	Range	Description
•	•	144	R/W	NV	UInt	Wh		10000, <b>1000</b> , 100, 10	Wh (& VARh, if equipped) Energy per Pulse Output Contact Closure. If the meter cannot find a pulse duration that will keep up with the max. system power (register 135), it will reject the new value. Check the meter configuration and/or try a larger value.  kWh (& VARh, if equipped) Pulse Contacts
•	•	145	R	NV	UInt	msec		500, 250, 100, 50, 25, 10	Pulse Contact Closure Duration in msec. Read-only. Set to the slowest duration that will keep up with the theoretical max. system power (register 135). The open time ≥ the closure time, so the max. pulse rate (pulses per sec) is the inverse of double the pulse time.  Note: The kWh pulse contact can keep up with a maximum power (Watts) of 1800000 x Wh pulse weight ÷ contact closure duration (in msec)
•	•	146	R		UInt				Error Bitmap. 1 = Active: Bit 0: Phase A Voltage out of range Bit 1: Phase B Voltage out of range Bit 2: Phase C Voltage out of range Bit 3: Phase A Current out of range Bit 4: Phase B Current out of range Bit 5: Phase C Current out of range Bit 6: Frequency out of the range of 45 to 65 Hz -OR- insufficient voltage to determine frequency. Bit 7: Reserved for future use Bit 8: Phase Loss A Bit 9: Phase Loss B Bit 10: Phase Loss C Bit 11: Low Power Factor on A with one or more phases having a PF less than 0.5 due to mis-wiring of phases Bit 12: Low Power Factor on B Bit 13: Low Power Factor on C Bit 14: Energy pulse output overrun error. The pulse outputs are unable to keep up with the total real power (registers 3 and 261/262). To fix, increase the pulse energy register (register 144) and reset the energy accumulators (see reset register 129). Bit 15: Energy pulse output configuration error (present pulse energy setting may not keep up with the theoretical max. system power; see register 135). To fix, increase the pulse energy (register 144).
•	•	147	R	NV	UInt			0-32767	Count of Energy Accumulator resets
•	•	148	R		UInt				Reserved (returns 0)
•	•	149	R/W	NV	UInt			1-6	Number of Sub-Intervals per Demand Interval. Sets the number of sub-intervals that make a single demand interval. For block demand, set this to 1. Default is 1. When Sub-Interval Length register #150 is set to 0 (sync-to-comms mode), this register is ignored.
•	•	150	R/W	NV	UInt	Seconds		0, 10-32767	Sub-Interval Length in seconds. For sync-to-comms, set this to 0 and use the reset register (129) to externally re-start the sub-interval. On the E51C3, this is also the logging interval.
•	•	151	R/W		UInt			1-32767	Reserved (returns 0)
•	•	152	R	NV	UInt			0-32767	Power Up Counter.
•	•	153	R	NV	UInt			0-32767	Output Configuration. E51C2 and E51C3 units have a NO energy contact and NC (Normally Closed - Form B) Phase Loss contact, so this register will always return a "0".
•	•	154	R		UInt				Reserved, returns 0

E51C2 FDS	E51C3 Log	Register	R/W	NV	Format	Units	Scale	Range	Description				
Logging Configuration and Status													
		• 155	R/W	NV	UInt	Day / Month		See Bytes	<table border="1"> <tr> <th>Most Significant Byte (MSB)</th> <th>Least Significant Byte (LSB)</th> </tr> <tr> <td>Day 1-31 (0x01-0x1F)</td> <td>Month 1-12 (0x01-0x0C)</td> </tr> </table>	Most Significant Byte (MSB)	Least Significant Byte (LSB)	Day 1-31 (0x01-0x1F)	Month 1-12 (0x01-0x0C)
Most Significant Byte (MSB)	Least Significant Byte (LSB)												
Day 1-31 (0x01-0x1F)	Month 1-12 (0x01-0x0C)												
		• 156	R/W	NV	UInt	Hour / Year		See Bytes	<table border="1"> <tr> <th>Hour 0-23 (0x00-0x17)</th> <th>Year 0-199 (0x00-0xC7)</th> </tr> </table>	Hour 0-23 (0x00-0x17)	Year 0-199 (0x00-0xC7)		
Hour 0-23 (0x00-0x17)	Year 0-199 (0x00-0xC7)												
		• 157	R/W	NV	UInt	Seconds / Minutes		See Bytes	<table border="1"> <tr> <th>Seconds 0-59 (0x00-0x3B)</th> <th>Minutes 0-59 (0x00-0x3B)</th> </tr> </table>	Seconds 0-59 (0x00-0x3B)	Minutes 0-59 (0x00-0x3B)		
Seconds 0-59 (0x00-0x3B)	Minutes 0-59 (0x00-0x3B)												
		• 158	R/W	NV	UInt			0-10	<p>Logging Read Page Register. Selects which of the Register Logs to read (see registers 169-178). 1-10 are valid entries that put the meter into log reading mode, temporarily pausing logging. When set to 0 (no variable selected for reading), normal logging resumes. The meter will buffer one set of log entries while in reading mode if a sub-interval timeout occurs (read/write collision). Default is 0.</p> <p>Warning: this buffered data will be written to the log, and logging will resume on the following sub-interval timeout whether the page register has been cleared or not, resulting in the appearance of data moving in the buffer during reads. To avoid this, log buffer reads should be completed and this register set back to 0 in less time than the Demand Sub-interval (preferred) or logging should be halted by setting Bit 1 in register 158 (logs may be missed)</p>				
		• 159	R/W	NV	UInt				<p>Logging Configuration Register (Bit Mapped):</p> <p>Bit 0: Clear to 0 for Circular log buffer mode. Set to 1 for single shot logging mode. Default is 0 (Circular).</p> <p>Bit 1: Clear to 0 to enable Logging. Set to 1 to halt logging. Default is 0 (Log).</p>				
		• 160	R	NV	UInt				<p>Logging Status Register (Bit Mapped):</p> <p>Bit 0: Log buffer full – Set to 1 when one single shot mode has filled the log buffer. In this condition, the Logged Entry Count will continue to increment. Cleared to 0 when logging is restarted (see reset command register 129).</p> <p>Bit 1: Log Buffer Read Collision 1 – Set to 1 if the meter tried to save log data while the user was reading the log (Logging Page Register has been set to something other than 0). On the first collision, the meter holds the data until the next sub-interval and then writes the saved data to the log as well as the data for that interval. This bit is cleared to 0 on the first demand interval with Logging Page Register = 0.</p> <p>Bit 2: Log Buffer Read Collision 2 – Set to 1 on the 2nd attempt to save log data while the user is reading the log (Logging Page Register is set to something other than 0). At this point the meter ignores the read condition and does a double write, first of the values saved from the previous cycle, and then the present values. If the read condition is not removed the meter continues to write the log data as it normally would. This bit is cleared to 0 on the first demand interval with Logging Page Register = 0.</p> <p>Bit 3: Logging Reset – The log has been reset during the previous demand sub-interval.</p> <p>Bit 4: Logging Interrupted – Logging has been interrupted (power cycled, log configuration change, etc.) during the previous demand sub-interval.</p> <p>Bit 5: RTC Changed – The real time clock had been changed during the previous demand subinterval.</p> <p>Bit 6: RTC Reset - The Real Time Clock has been reset to the year 2000 and needs to be re-initialized.</p>				
		• 161	R	NV	UInt			0-32767	Log Buffer Wrap / Missed Log Counter. In continuous mode, this counter increments each time the internal circular log buffer wraps and overwrites old data. The total number of logged entries since the last log reset is: (Register 161 x 5760) + Register 163. In single shot mode this counter is the number of log entries lost due to the buffer being full. The counter is cleared on logging reset.				
		• 162	R	NV	UInt			0-32767	Max Number of Logging Days. Based on the Sub-Interval Length and the depth of the log buffer, this register shows the maximum number of days that data will be logged following a reset until the Buffer is full (Single Shot Mode) or overwrites old data (Continuous).				
		• 163	R	NV	UInt			0-32767	Number of Logged Entries since the log buffer wrapped or was reset. In single shot mode, this is the total number of valid entries in the buffer. Any entries beyond this will read back as QNAN (0x8000).				
		• 164	R	NV	ULong	kWh	E	0-0xFFFF	Real Energy Consumption (MSR)	Real Energy (Register 001/002) starting value. Corresponds to when logging is started, reset, or rolls.			
		• 165						0-0xFFFF			Real Energy Consumption (LSR)		
		• 166	R	NV	UInt	Month / Day		See Bytes	<table border="1"> <tr> <th>Most Significant Byte (MSB)</th> <th>Least Significant Byte (LSB)</th> </tr> <tr> <td>Day 1-31 (0x01-0x1F)</td> <td>Month 1-12 (0x01-0x0C)</td> </tr> </table>	Most Significant Byte (MSB)	Least Significant Byte (LSB)	Day 1-31 (0x01-0x1F)	Month 1-12 (0x01-0x0C)
Most Significant Byte (MSB)	Least Significant Byte (LSB)												
Day 1-31 (0x01-0x1F)	Month 1-12 (0x01-0x0C)												
		• 167	R	NV	UInt	Year / Hour		See Bytes	<table border="1"> <tr> <th>Hour 0-23 (0x00-0x17)</th> <th>Year 0-199 (0x00-0xC7)</th> </tr> </table>	Hour 0-23 (0x00-0x17)	Year 0-199 (0x00-0xC7)		
Hour 0-23 (0x00-0x17)	Year 0-199 (0x00-0xC7)												
		• 168	R	NV	UInt	Minutes / Seconds		See Bytes	<table border="1"> <tr> <th>Seconds 0-59 (0x00-0x3B)</th> <th>Minutes 0-59 (0x00-0x3B)</th> </tr> </table>	Seconds 0-59 (0x00-0x3B)	Minutes 0-59 (0x00-0x3B)		
Seconds 0-59 (0x00-0x3B)	Minutes 0-59 (0x00-0x3B)												

E51C2 FDS	E51C3 Log	Register	R/W	NV	Format	Units	Scale	Range	Description		
	•	169	R/W	NV	UInt			1-42, 146, 155-157, 257-336	Log Register 1 – Default is 3 (Import Real Energy MSR)	Log Register Selection – Write the number of the 16 bit register to be logged. To log a 32 bit value (such as accumulators and floating point values) two log registers must be used, one each for the most and least significant register (MSR & LSR).	
	•	170	R/W	NV	UInt				Log Register 2 – Default is 4 (Import Real Energy LSR)		
	•	171	R/W	NV	UInt				Log Register 3 – Default is 5 (Export Real Energy MSR)		
	•	172	R/W	NV	UInt				Log Register 4 – Default is 6 (Export Real Energy LSR)		
	•	173	R/W	NV	UInt				Log Register 5 – Default is 29 (Real Demand)		
	•	174	R/W	NV	UInt				Log Register 6 – Default is 30 (Reactive Demand)		
	•	175	R/W	NV	UInt				Log Register 7 – Default is 31 (Apparent Demand)		
	•	176	R/W	NV	UInt				Log Register 8 – Default is 155 (Month/Day)		
	•	177	R/W	NV	UInt				Log Register 9 – Default is 156 (Year/Hour)		
	•	178	R/W	NV	UInt				Log Register 10 – Default is 157 (Minutes/Seconds)		
Floating Point Data: Summary of Active Phases											
•	•	257/258	R	NV	Float	kWh			Accumulated Real Energy: Net (Import - Export)	Accumulated Real Energy (Ph)	Clear via register 129
•	•	259/260	R	NV	Float	kWh			Real Energy: Quadrants 1 & 4 Import		
•	•	261/262	R		Float	kWh			Real Energy: Quadrants 2 & 3 Export		
•	•	263/264	R		Float	kVARh			Reactive Energy: Quadrant 1 Lags Import Real Energy (IEC) Inductive (IEEE)	Accumulated Reactive Energy (Qh): Quadrants 1+2= Import Quadrants 3+4= Export	
•	•	265/266	R		Float	kVARh			Reactive Energy: Quadrant 2 Leads Export Real Energy (IEC) Inductive (IEEE)		
•	•	267/268	R		Float	kVARh			Reactive Energy: Quadrant 3 Lags Export Real Energy (IEC) Capacitive (IEEE)		
•	•	269/270	R		Float	kVARh			Reactive Energy: Quadrant 4 Leads Import Real Energy (IEC) Capacitive (IEEE)		
•	•	271/272	R	NV	Float	kVAh			Apparent Energy: Net (Import - Export)	Accumulated Apparent Energy (Sh): Import and Export correspond with Real Energy	
•	•	273/274	R	NV	Float	kVAh			Apparent Energy: Quadrants 1 & 4 Import		
•	•	275/276	R	NV	Float	kVAh			Apparent Energy: Quadrants 2 & 3 Export		
•	•	277/278	R		Float	kW			Total Net Instantaneous Real (P) Power		
•	•	279/280	R		Float	kVAR			Total Net Instantaneous Reactive (Q) Power		
•	•	281/282	R		Float	kVA			Total Net Instantaneous Apparent (S) Power		
•	•	283/284	R		Float	Ratio		0.0-1.0	Total Power Factor (Total kW / Total kVA)		
•	•	285/286	R		Float	Volt			Voltage, L-L (U), average of active phases		
•	•	287/288	R		Float	Volt			Voltage, L-N (V), average of active phases		
•	•	289/290	R		Float	Amp			Current, average of active phases		
•	•	291/292	R		Float	Hz		45.0-65.0	Frequency		
•	•	293/294	R		Float	kW			Total Real Power Present Demand		
•	•	295/296	R		Float	kVAR			Total Reactive Power Present Demand		
•	•	297/298	R		Float	kVA			Total Apparent Power Present Demand		

E51C2 FDS	E51C3 Log	Register	R/W	NV	Format	Units	Scale	Range	Description
•	•	299/300	R	NV	Float	kW			Total Real Power Max. Demand
•	•	301/302	R	NV	Float	kVAR			Total Reactive Power Max. Demand
•	•	303/304	R	NV	Float	kVA			Total Apparent Power Max. Demand
•	•	305/306	R	NV	Float	kW			Total Real Power Max. Demand
•	•	307/308	R	NV	Float	kVAR			Total Reactive Power Max. Demand
•	•	309/310	R	NV	Float	kVA			Total Apparent Power Max. Demand
•	•	311/312	R		Float				Reserved, reports QNAN (0x7FC00000)
•	•	313/314	R		Float		1	0-4294967040	Pulse Counter 1 (Import Real Energy)
•	•	315/316	R		Float		1	0-4294967040	Pulse Counter 2 (Export Reactive Energy)
Contact closure counters. Valid for both pulse inputs and outputs. E51Cx counts are shown in (). See register 144 for the weight of each pulse output count. These values are derived from the 32 bit integer counter and will roll over to 0 when the integer counters do. Inputs are user defined.									
Floating Point Data: Per Phase									
•	•	317/318	R		Float	kWh			Accumulated Real Energy, Phase A
•	•	319/320	R		Float	kWh			Accumulated Real Energy, Phase B
•	•	321/322	R		Float	kWh			Accumulated Real Energy, Phase C
•	•	323/324	R		Float	kWh			Accumulated Real Energy, Phase A
•	•	325/326	R		Float	kWh			Accumulated Real Energy, Phase B
•	•	327/328	R		Float	kWh			Accumulated Real Energy, Phase C
•	•	329/330	R		Float	kVARh			Accumulated Q1 Reactive Energy, Phase A
•	•	331/332	R		Float	kVARh			Accumulated Q1 Reactive Energy, Phase B
•	•	333/334	R		Float	kVARh			Accumulated Q1 Reactive Energy, Phase C
•	•	335/336	R		Float	kVARh			Accumulated Q2 Reactive Energy, Phase A
•	•	337/338	R		Float	kVARh			Accumulated Q2 Reactive Energy, Phase B
•	•	339/340	R		Float	kVARh			Accumulated Q2 Reactive Energy, Phase C
•	•	341/342	R		Float	kVARh			Accumulated Q3 Reactive Energy, Phase A
•	•	343/344	R		Float	kVARh			Accumulated Q3 Reactive Energy, Phase B
•	•	345/346	R		Float	kVARh			Accumulated Q3 Reactive Energy, Phase C
•	•	347/348	R		Float	kVARh			Accumulated Q4 Reactive Energy, Phase A
•	•	349/350	R		Float	kVARh			Accumulated Q4 Reactive Energy, Phase B
•	•	351/352	R		Float	kVARh			Accumulated Q4 Reactive Energy, Phase C
•	•	353/354	R		Float	kVAh			Accumulated Apparent Energy, Phase A
•	•	355/356	R		Float	kVAh			Accumulated Apparent Energy, Phase B
•	•	357/358	R		Float	kVAh			Accumulated Apparent Energy, Phase C
•	•	359/360	R		Float	kVAh			Accumulated Apparent Energy, Phase A
•	•	361/362	R		Float	kVAh			Accumulated Apparent Energy, Phase B
•	•	363/364	R		Float	kVAh			Accumulated Apparent Energy, Phase C
•	•	365/366	R		Float	kW			Real Power, Phase A
•	•	367/368	R		Float	kW			Real Power, Phase A
•	•	369/370	R		Float	kW			Real Power, Phase A
•	•	371/372	R		Float	kVAR			Reactive Power, Phase A
•	•	373/374	R		Float	kVAR			Reactive Power, Phase A
•	•	375/376	R		Float	kVAR			Reactive Power, Phase A
•	•	377/378	R		Float	kVA			Apparent Power, Phase A
•	•	379/380	R		Float	kVA			Apparent Power, Phase A
•	•	381/382	R		Float	kVA			Apparent Power, Phase A
•	•	383/384	R		Float	Ratio		0.0-1.0	Power Factor, Phase A
•	•	385/386	R		Float	Ratio		0.0-1.0	Power Factor, Phase A
•	•	387/388	R		Float	Ratio		0.0-1.0	Power Factor, Phase A



E51C2 FDS	E51C3 Log	Register	R/W	NV	Format	Units	Scale	Range	Description
•	•	389/390	R		Float	Volt			Voltage, Phase A-B
•	•	391/392	R		Float	Volt			Voltage, Phase B-C
•	•	393/394	R		Float	Volt			Voltage, Phase A-C
•	•	395/396	R		Float	Volt			Voltage, Phase A-N
•	•	397/398	R		Float	Volt			Voltage, Phase B-N
•	•	399/400	R		Float	Volt			Voltage, Phase C-N
•	•	401/402	R		Float	Amp			Current, Phase A
•	•	403/404	R		Float	Amp			Current, Phase B
•	•	405/406	R		Float	Amp			Current, Phase C
•	•	407/408	R		Float				Reserved, Reports QNAN (0x7FC00000)
Logging Interface									
	•	8000	R	NV					Newest Logged Data Entry
		(to)							(to)
									5760 entries total (60 days at a 15 minute sub-interval)
	•	13760	R	NV					Oldest Logged Data Entry

Invalid or Quiet Not A Number (QNAN) conditions are indicated by 0x8000 (negative zero) for 16 bit integers and 0x7FC00000 for 32 bit floating point numbers.

Floating point numbers are encoded per the IEEE 754 32-bit specifications.

**SunSpec Compliant Common and Meter Model Register Blocks**

See [www.sunspec.org](http://www.sunspec.org) for the original specifications.

E51C2 FDS	E51C3 Log	Register	R/W	NV	Format	Units	Scale	Range	SunSpec Name	Description
<b>SunSpec 1.0 Common Model</b>										
•	•	40001	R	NV	ULong			0x5375 6e53	C_SunSpec_ID	ASCII "SunS". Identifies this as the beginning of a SunSpec Modbus point
•	•	40002								
•	•	40003	R	NV	UInt			1	C_SunSpec_DID	SunSpec common model Device ID
•	•	40004	R	NV	UInt			65	C_SunSpec_Length	Length of the common model block
•	•	40005 to 40020	R	NV	String (32)	ASCII			C_Manufacturer	null terminated ASCII text string = "VERIS"
•	•	40021 to 40036	R	NV	String (32)	ASCII			C_Model	null terminated ASCII text string = "E51C_"
•	•	40037 to 40044	R	NV	String (16)	ASCII			C_Options	null terminated ASCII text string
•	•	40045 to 40052	R	NV	String (16)	ASCII			C_Version	null terminated ASCII text string
•	•	40053 to 40068	R	NV	String (32)	ASCII			C_SerialNumber	null terminated ASCII text string
•	•	40068	R	NV	UInt	ASCII			C_SunSpec_Length	Modbus address
<b>SunSpec 1.1 Integer Meter Model</b>										
Identification										
•	•	40070	R	NV	UInt			201 to 204	C_SunSpec_DID	SunSpec Integer meter model device IDs. Meter configuration by device ID: 201 = single phase (A-N or A-B) meter 202 = split single phase (A-B-N) meter 203 = Wye-connect 3-phase (ABCN) meter 204 = delta-connect 3-phase (ABC) meter
•	•	40071	R	NV	UInt			105	C_SunSpec_Length	Length of the meter model block

E51C2 FDS	E51C3 Log	Register	R/W	NV	Format	Units	Scale	Range	SunSpec Name	Description
<b>Current</b>										
•	•	40072	R		SInt	Amps	M_AC_Current_SF	-32767 to +32767	M_AC_Current	AC Current (sum of active phases)
•	•	40073	R		SInt	Amps	M_AC_Current_SF	-32767 to +32767	M_AC_Current_A	Phase A AC current
•	•	40074	R		SInt	Amps	M_AC_Current_SF	-32767 to +32767	M_AC_Current_B	Phase B AC current
•	•	40075	R		SInt	Amps	M_AC_Current_SF	-32767 to +32767	M_AC_Current_C	Phase C AC current
•	•	40076	R	NV	SInt				M_AC_Current_CN	AC Current Scale Factor
<b>Voltage: Line to Neutral</b>										
•	•	40077	R		SInt	Volts	M_AC_Voltage_SF	-32767 to +32767	M_AC_Voltage_LN	Line to Neutral AC voltage (average of active phases)
•	•	40078	R		SInt	Volts	M_AC_Voltage_SF	-32767 to +32767	M_AC_Voltage_AN	Phase A to Neutral AC Voltage
•	•	40079	R		SInt	Volts	M_AC_Voltage_SF	-32767 to +32767	M_AC_Voltage_BN	Phase B to Neutral AC Voltage
•	•	40080	R		SInt	Volts	M_AC_Voltage_SF	-32767 to +32767	M_AC_Voltage_CN	Phase C to Neutral AC Voltage
<b>Voltage: Line to Line</b>										
•	•	40081	R		SInt	Volts	M_AC_Voltage_SF	-32767 to +32767	M_AC_Voltage_LL	Line to Line AC voltage (average of active phases)
•	•	40082	R		SInt	Volts	M_AC_Voltage_SF	-32767 to +32767	M_AC_Voltage_AB	Phase A to Phase B AC Voltage
•	•	40083	R		SInt	Volts	M_AC_Voltage_SF	-32767 to +32767	M_AC_Voltage_BC	Phase B to Phase C AC Voltage
•	•	40084	R		SInt	Volts	M_AC_Voltage_SF	-32767 to +32767	M_AC_Voltage_CA	Phase C to Phase A AC Voltage
•	•	40085	R	NV	SInt				M_AC_Voltage_SF	AC Voltage Scale Factor
<b>Frequency</b>										
•	•	40086	R		SInt	Hertz	M_AC_Freq_SF	-32767 to +32767	M_AC_Freq	AC Frequency
•	•	40087	R	NV	SInt	SF			M_AC_Freq_SF	AC Frequency Scale Factor
<b>Power</b>										
<b>Real Power</b>										
•	•	40088	R		SInt	Watts	M_AC_Power_SF	-32767 to +32767	M_AC_Power	Total Real Power (sum of active phases)
•	•	40089	R		SInt	Watts	M_AC_Power_SF	-32767 to +32767	M_AC_Power_A	Phase A AC Real Power
•	•	40090	R		SInt	Watts	M_AC_Power_SF	-32767 to +32767	M_AC_Power_B	Phase B AC Real Power
•	•	40091	R		SInt	Watts	M_AC_Power_SF	-32767 to +32767	M_AC_Power_C	Phase A AC Real Power
•	•	40092	R	NV	SInt	SF			M_AC_Power_SF	AC Real Power Scale Factor
<b>Apparent Power</b>										
•	•	40093	R		SInt	Volt-Amps	M_AC_VA_SF	-32767 to +32767	M_AC_VA	Total AC Apparent Power (sum of active phases)
•	•	40094	R		SInt	Volt-Amps	M_AC_VA_SF	-32767 to +32767	M_AC_VA_A	Phase A AC Apparent Power
•	•	40095	R		SInt	Volt-Amps	M_AC_VA_SF	-32767 to +32767	M_AC_VA_B	Phase B AC Apparent Power
•	•	40096	R		SInt	Volt-Amps	M_AC_VA_SF	-32767 to +32767	M_AC_VA_C	Phase A AC Apparent Power
•	•	40097	R	NV	SInt	SF			M_AC_VA_SF	AC Apparent Power Scale Factor
<b>Reactive Power</b>										
•	•	40098	R		SInt	VAR	M_AC_VAR_SF	-32767 to +32767	M_AC_VAR	Total AC Reactive Power (sum of active phases)
•	•	40099	R		SInt	VAR	M_AC_VAR_SF	-32767 to +32767	M_AC_VAR_A	Phase A AC Reactive Power
•	•	40100	R		SInt	VAR	M_AC_VAR_SF	-32767 to +32767	M_AC_VAR_B	Phase B AC Reactive Power
•	•	40101	R		SInt	VAR	M_AC_VAR_SF	-32767 to +32767	M_AC_VAR_C	Phase A AC Reactive Power
•	•	40102	R	NV	SInt	SF			M_AC_VAR_SF	AC Reactive Power Scale Factor
<b>Power Factor</b>										
•	•	40103	R		SInt	%	M_AC_PF_SF	-32767 to +32767	M_AC_PF	Average Power Factor (average of active phases)
•	•	40104	R		SInt	%	M_AC_PF_SF	-32767 to +32767	M_AC_PF_A	Phase A Power Factor
•	•	40105	R		SInt	%	M_AC_PF_SF	-32767 to +32767	M_AC_PF_B	Phase B Power Factor
•	•	40106	R		SInt	%	M_AC_PF_SF	-32767 to +32767	M_AC_PF_C	Phase A Power Factor
•	•	40107	R	NV	SInt	SF			M_AC_PF_SF	AC Power Factor Scale Factor

E51C2 FDS	E51C3 Log	Register	R/W	NV	Format	Units	Scale	Range	SunSpec Name	Description
<b>Accumulated Energy</b>										
Real Energy										
• •	40108	R	NV	ULong	Watt-hours	M_Energy_W_SF	0x0 to 0xFFFFFFFF	M_Exported_W	Total Exported Real Energy	
• •	40109	R	NV	ULong	Watt-hours	M_Energy_W_SF	0x0 to 0xFFFFFFFF	M_Exported_W_A	Phase A Exported Real Energy	
• •	40110	R	NV	ULong	Watt-hours	M_Energy_W_SF	0x0 to 0xFFFFFFFF	M_Exported_W_B	Phase B Exported Real Energy	
• •	40111	R	NV	ULong	Watt-hours	M_Energy_W_SF	0x0 to 0xFFFFFFFF	M_Exported_W_C	Phase C Exported Real Energy	
• •	40112	R	NV	ULong	Watt-hours	M_Energy_W_SF	0x0 to 0xFFFFFFFF	M_Imported_W	Total Imported Real Energy	
• •	40113	R	NV	ULong	Watt-hours	M_Energy_W_SF	0x0 to 0xFFFFFFFF	M_Imported_W_A	Phase A Imported Real Energy	
• •	40114	R	NV	ULong	Watt-hours	M_Energy_W_SF	0x0 to 0xFFFFFFFF	M_Imported_W_B	Phase B Imported Real Energy	
• •	40115	R	NV	ULong	Watt-hours	M_Energy_W_SF	0x0 to 0xFFFFFFFF	M_Imported_W_C	Phase C Imported Real Energy	
• •	40116	R	NV	ULong	Watt-hours	M_Energy_W_SF	0x0 to 0xFFFFFFFF	M_Energy_W_SF	Real Energy Scale Factor	
• •	40117	R	NV	ULong	Watt-hours	M_Energy_W_SF	0x0 to 0xFFFFFFFF	M_Energy_W_SF	Real Energy Scale Factor	
• •	40118	R	NV	ULong	Watt-hours	M_Energy_W_SF	0x0 to 0xFFFFFFFF	M_Energy_W_SF	Real Energy Scale Factor	
• •	40119	R	NV	ULong	Watt-hours	M_Energy_W_SF	0x0 to 0xFFFFFFFF	M_Energy_W_SF	Real Energy Scale Factor	
• •	40120	R	NV	ULong	Watt-hours	M_Energy_W_SF	0x0 to 0xFFFFFFFF	M_Energy_W_SF	Real Energy Scale Factor	
• •	40121	R	NV	ULong	Watt-hours	M_Energy_W_SF	0x0 to 0xFFFFFFFF	M_Energy_W_SF	Real Energy Scale Factor	
• •	40122	R	NV	ULong	Watt-hours	M_Energy_W_SF	0x0 to 0xFFFFFFFF	M_Energy_W_SF	Real Energy Scale Factor	
• •	40123	R	NV	ULong	Watt-hours	M_Energy_W_SF	0x0 to 0xFFFFFFFF	M_Energy_W_SF	Real Energy Scale Factor	
• •	40124	R	NV	SF	SF	1		M_Energy_W_SF	Real Energy Scale Factor	
Apparent Energy										
• •	40125	R	NV	ULong	VA-hours	M_Energy_VA_SF	0x0 to 0xFFFFFFFF	M_Exported_VA	Total Exported Apparent Energy	
• •	40126	R	NV	ULong	VA-hours	M_Energy_VA_SF	0x0 to 0xFFFFFFFF	M_Exported_VA_A	Phase A Exported Apparent Energy	
• •	40127	R	NV	ULong	VA-hours	M_Energy_VA_SF	0x0 to 0xFFFFFFFF	M_Exported_VA_B	Phase B Exported Apparent Energy	
• •	40128	R	NV	ULong	VA-hours	M_Energy_VA_SF	0x0 to 0xFFFFFFFF	M_Exported_VA_C	Phase C Exported Apparent Energy	
• •	40129	R	NV	ULong	VA-hours	M_Energy_VA_SF	0x0 to 0xFFFFFFFF	M_Imported_VA	Total Imported Apparent Energy	
• •	40130	R	NV	ULong	VA-hours	M_Energy_VA_SF	0x0 to 0xFFFFFFFF	M_Imported_VA_A	Phase A Imported Apparent Energy	
• •	40131	R	NV	ULong	VA-hours	M_Energy_VA_SF	0x0 to 0xFFFFFFFF	M_Imported_VA_B	Phase B Imported Apparent Energy	
• •	40132	R	NV	ULong	VA-hours	M_Energy_VA_SF	0x0 to 0xFFFFFFFF	M_Imported_VA_C	Phase C Imported Apparent Energy	
• •	40133	R	NV	ULong	VA-hours	M_Energy_VA_SF	0x0 to 0xFFFFFFFF	M_Energy_VA_SF	Real Energy Scale Factor	
• •	40134	R	NV	ULong	VA-hours	M_Energy_VA_SF	0x0 to 0xFFFFFFFF	M_Energy_VA_SF	Real Energy Scale Factor	
• •	40135	R	NV	ULong	VA-hours	M_Energy_VA_SF	0x0 to 0xFFFFFFFF	M_Energy_VA_SF	Real Energy Scale Factor	
• •	40136	R	NV	ULong	VA-hours	M_Energy_VA_SF	0x0 to 0xFFFFFFFF	M_Energy_VA_SF	Real Energy Scale Factor	
• •	40137	R	NV	ULong	VA-hours	M_Energy_VA_SF	0x0 to 0xFFFFFFFF	M_Energy_VA_SF	Real Energy Scale Factor	
• •	40138	R	NV	ULong	VA-hours	M_Energy_VA_SF	0x0 to 0xFFFFFFFF	M_Energy_VA_SF	Real Energy Scale Factor	
• •	40139	R	NV	ULong	VA-hours	M_Energy_VA_SF	0x0 to 0xFFFFFFFF	M_Energy_VA_SF	Real Energy Scale Factor	
• •	40140	R	NV	ULong	VA-hours	M_Energy_VA_SF	0x0 to 0xFFFFFFFF	M_Energy_VA_SF	Real Energy Scale Factor	
• •	40141	R	NV	UInt	SF	1		M_Energy_VA_SF	Real Energy Scale Factor	
Reactive Energy										
• •	40142	R	NV	ULong	VAR-hours	M_Energy_VAR_SF	0x0 to 0xFFFFFFFF	M_Import_VARh_Q1	Quadrant 1: Total Imported Reactive Energy	
• •	40143	R	NV	ULong	VAR-hours	M_Energy_VAR_SF	0x0 to 0xFFFFFFFF	M_Import_VARh_Q1A	Phase A - Quadrant 1: Total Imported Reactive Energy	
• •	40144	R	NV	ULong	VAR-hours	M_Energy_VAR_SF	0x0 to 0xFFFFFFFF	M_Import_VARh_Q1B	Phase B - Quadrant 1: Total Imported Reactive Energy	
• •	40145	R	NV	ULong	VAR-hours	M_Energy_VAR_SF	0x0 to 0xFFFFFFFF	M_Import_VARh_Q1C	Phase C - Quadrant 1: Total Imported Reactive Energy	
• •	40146	R	NV	ULong	VAR-hours	M_Energy_VAR_SF	0x0 to 0xFFFFFFFF	M_Import_VARh_Q2	Quadrant 2: Total Imported Reactive Energy	
• •	40147	R	NV	ULong	VAR-hours	M_Energy_VAR_SF	0x0 to 0xFFFFFFFF	M_Import_VARh_Q2A	Phase A - Quadrant 2: Total Imported Reactive Energy	
• •	40148	R	NV	ULong	VAR-hours	M_Energy_VAR_SF	0x0 to 0xFFFFFFFF	M_Import_VARh_Q2B	Phase B - Quadrant 2: Total Imported Reactive Energy	
• •	40149	R	NV	ULong	VAR-hours	M_Energy_VAR_SF	0x0 to 0xFFFFFFFF	M_Import_VARh_Q2C	Phase C - Quadrant 2: Total Imported Reactive Energy	
• •	40150	R	NV	ULong	VAR-hours	M_Energy_VAR_SF	0x0 to 0xFFFFFFFF	M_Import_VARh_Q2D	Phase D - Quadrant 2: Total Imported Reactive Energy	
• •	40151	R	NV	ULong	VAR-hours	M_Energy_VAR_SF	0x0 to 0xFFFFFFFF	M_Import_VARh_Q2E	Phase E - Quadrant 2: Total Imported Reactive Energy	
• •	40152	R	NV	ULong	VAR-hours	M_Energy_VAR_SF	0x0 to 0xFFFFFFFF	M_Import_VARh_Q2F	Phase F - Quadrant 2: Total Imported Reactive Energy	
• •	40153	R	NV	ULong	VAR-hours	M_Energy_VAR_SF	0x0 to 0xFFFFFFFF	M_Import_VARh_Q2G	Phase G - Quadrant 2: Total Imported Reactive Energy	

E51C2 FDS	E51C3 Log	Register	R/W	NV	Format	Units	Scale	Range	SunSpec Name	Description																											
• •	40154	R	NV	ULong	VAR-hours	M_Energy_VAR_SF	0x0 to 0xFFFFFFFF	M_Import_VARh_Q2B	Phase B - Quadrant 2: Total Imported Reactive Energy																												
• •	40155								Phase C - Quadrant 2: Total Imported Reactive Energy																												
• •	40156	R	NV	ULong	VAR-hours	M_Energy_VAR_SF	0x0 to 0xFFFFFFFF	M_Import_VARh_Q2C	Phase C - Quadrant 2: Total Imported Reactive Energy																												
• •	40157								Phase C - Quadrant 2: Total Imported Reactive Energy																												
• •	40158	R	NV	ULong	VAR-hours	M_Energy_VAR_SF	0x0 to 0xFFFFFFFF	M_Export_VARh_Q3	Quadrant 3: Total Exported Reactive Energy																												
• •	40159								Quadrant 3: Total Exported Reactive Energy																												
• •	40160	R	NV	ULong	VAR-hours	M_Energy_VAR_SF	0x0 to 0xFFFFFFFF	M_Export_VARh_Q3A	Phase A - Quadrant 3: Total Exported Reactive Energy																												
• •	40161								Phase A - Quadrant 3: Total Exported Reactive Energy																												
• •	40162	R	NV	ULong	VAR-hours	M_Energy_VAR_SF	0x0 to 0xFFFFFFFF	M_Export_VARh_Q3B	Phase B - Quadrant 3: Total Exported Reactive Energy																												
• •	40163								Phase B - Quadrant 3: Total Exported Reactive Energy																												
• •	40164	R	NV	ULong	VAR-hours	M_Energy_VAR_SF	0x0 to 0xFFFFFFFF	M_Export_VARh_Q3C	Phase C - Quadrant 3: Total Exported Reactive Energy																												
• •	40165								Phase C - Quadrant 3: Total Exported Reactive Energy																												
• •	40166	R	NV	ULong	VAR-hours	M_Energy_VAR_SF	0x0 to 0xFFFFFFFF	M_Export_VARh_Q4	Quadrant 4: Total Exported Reactive Energy																												
• •	40167								Quadrant 4: Total Exported Reactive Energy																												
• •	40168	R	NV	ULong	VAR-hours	M_Energy_VAR_SF	0x0 to 0xFFFFFFFF	M_Export_VARh_Q4A	Phase A - Quadrant 4: Total Exported Reactive Energy																												
• •	40169								Phase A - Quadrant 4: Total Exported Reactive Energy																												
• •	40170	R	NV	ULong	VAR-hours	M_Energy_VAR_SF	0x0 to 0xFFFFFFFF	M_Export_VARh_Q4B	Phase B - Quadrant 4: Total Exported Reactive Energy																												
• •	40171								Phase B - Quadrant 4: Total Exported Reactive Energy																												
• •	40172	R	NV	ULong	VAR-hours	M_Energy_VAR_SF	0x0 to 0xFFFFFFFF	M_Export_VARh_Q4C	Phase C - Quadrant 4: Total Exported Reactive Energy																												
• •	40173								Phase C - Quadrant 4: Total Exported Reactive Energy																												
• •	40174	R	NV	UInt	SF	1		M_Energy_VA_SF	Reactive Energy Scale Factor																												
<b>Events</b>																																					
• •	40175							M_Events	Bit Map. See M_EVENT_flags. 0 = no event																												
• •	40176	R	NV	ULong	Flags																																
										<table border="1"> <thead> <tr> <th>Event</th> <th>Bit</th> <th>Description</th> </tr> </thead> <tbody> <tr> <td>M_EVENT_Power_Failure</td> <td>0x00000004</td> <td>Loss of power or phase</td> </tr> <tr> <td>M_EVENT_Under_Voltage</td> <td>0x00000008</td> <td>Voltage below threshold (phase loss)</td> </tr> <tr> <td>M_EVENT_Low_PF</td> <td>0x00000010</td> <td>Power factor below threshold (can indicate misassociated voltage and current inputs in 3-phase systems)</td> </tr> <tr> <td>M_EVENT_Over_Current</td> <td>0x00000020</td> <td>Current input over threshold (out of measurement range)</td> </tr> <tr> <td>M_EVENT_Over_Voltage</td> <td>0x00000040</td> <td>Voltage input over threshold (out of measurement range)</td> </tr> <tr> <td>M_EVENT_Missing_Sensor</td> <td>0x00000080</td> <td>Sensor not connected (not supported)</td> </tr> <tr> <td>M_EVENT_Reserved1-8</td> <td>0x00000100 to 0x00008000</td> <td>Reserved for future SunSpec use</td> </tr> <tr> <td>M_EVENT_OEM1-15</td> <td>0x7FFF000</td> <td>Reserved for OEMs (not used)</td> </tr> </tbody> </table>	Event	Bit	Description	M_EVENT_Power_Failure	0x00000004	Loss of power or phase	M_EVENT_Under_Voltage	0x00000008	Voltage below threshold (phase loss)	M_EVENT_Low_PF	0x00000010	Power factor below threshold (can indicate misassociated voltage and current inputs in 3-phase systems)	M_EVENT_Over_Current	0x00000020	Current input over threshold (out of measurement range)	M_EVENT_Over_Voltage	0x00000040	Voltage input over threshold (out of measurement range)	M_EVENT_Missing_Sensor	0x00000080	Sensor not connected (not supported)	M_EVENT_Reserved1-8	0x00000100 to 0x00008000	Reserved for future SunSpec use	M_EVENT_OEM1-15	0x7FFF000	Reserved for OEMs (not used)
Event	Bit	Description																																			
M_EVENT_Power_Failure	0x00000004	Loss of power or phase																																			
M_EVENT_Under_Voltage	0x00000008	Voltage below threshold (phase loss)																																			
M_EVENT_Low_PF	0x00000010	Power factor below threshold (can indicate misassociated voltage and current inputs in 3-phase systems)																																			
M_EVENT_Over_Current	0x00000020	Current input over threshold (out of measurement range)																																			
M_EVENT_Over_Voltage	0x00000040	Voltage input over threshold (out of measurement range)																																			
M_EVENT_Missing_Sensor	0x00000080	Sensor not connected (not supported)																																			
M_EVENT_Reserved1-8	0x00000100 to 0x00008000	Reserved for future SunSpec use																																			
M_EVENT_OEM1-15	0x7FFF000	Reserved for OEMs (not used)																																			
<b>End of SunSpec Block</b>																																					
• •	40177	R	NV	UInt			0xFFFF		C_SunSpec_DID = 0xFFFF Uniquely identifies this as the last SunSpec block																												
• •	40178	R	NV	UInt			0x0000		C_SunSpec_Length = 0 Last block has no length																												

**TROUBLESHOOTING**

Problem	Cause	Solution
The maintenance wrench icon appears in the power meter display.	There is a problem with the inputs to the power meter.	See the Alert sub-menu or the Diagnostic Alert Modbus Register 146
The display is blank after applying control power to the meter.	The meter is not receiving adequate power.	Verify that the meter control power are receiving the required voltage. Verify that the heart icon is blinking. Check the fuse.
The data displayed is inaccurate.	Incorrect setup values	Verify the values entered for power meter setup parameters (CT and PT ratings, system type, etc.). See the Setup section.
	Incorrect voltage inputs	Check power meter voltage input terminals to verify adequate voltage.
	Power meter is wired improperly.	Check all CTs and PTs to verify correct connection to the same service, CT and PT polarity, and adequate powering. See the Wiring Diagrams section for more information.
Cannot communicate with power meter from a remote personal computer.	Power meter address is incorrect.	Verify that the meter is correctly addressed (see Setup section).
	Power meter baud rate is incorrect.	Verify that the baud rate of the meter matches that of all other devices on its communications link (see Setup section).
	Communications lines are improperly connected.	Verify the power meter communications connections (see the Communications section). Verify the terminating resistors are properly installed on both ends of a chain of units. Units in the middle of a chain should not have a terminator. Verify the shield ground is connected between all units.
Sign of one phase (real power) is incorrect	CT orientation reversed	Remove CT, reverse orientation, reconnect (qualified personnel only)

**CHINA ROHS COMPLIANCE INFORMATION (EFUP TABLE)**

部件名称	产品中有毒有害物质或元素的名称及含量Substances					
	铅 (Pb)	汞 (Hg)	镉 (Cd)	六价铬 (Cr (VI))	多溴联苯 (PBB)	多溴二苯醚 (PBDE)
电子线路板	X	0	0	0	0	0
0 = 表示该有毒有害物质在该部件所有均质材料中的含量均在 SJ/T11363-2006 标准规定的限量要求以下。 X = 表示该有毒有害物质至少在该部件的某一均质材料中的含量超出SJ/T11363-2006标准规定的限量要求。						
Z000057-0A						